

Linearly distributive functors

J.R.B. Cockett ^{a,1} R.A.G. Seely ^{b,2}

^a *Department of Computer Science, University of Calgary, 2500 University Drive, Calgary, AL, T2N1N4, Canada.*

^b *Department of Mathematics, McGill University, 805 Sherbrooke St., Montréal, QC, H3A 2K6, Canada.*

Presented to Michael Barr to mark the occasion of his 60th birthday

Abstract

This paper introduces a notion of “linear functor” between linearly distributive categories that is general enough to account for common structure in linear logic, such as the exponentials ($!$, $?$), and the additives (product, coproduct), and yet when interpreted in the doctrine of $*$ -autonomous categories, gives the familiar notion of monoidal functor. We show that there is a bi-adjunction between the 2-categories of linearly distributive categories and linear functors, and of $*$ -autonomous categories and monoidal functors, given by the construction of the “nucleus” of a linearly distributive category. We develop a calculus of proof nets for linear functors, and show how linearity accounts for the essential coherence structure of the exponentials and the additives.

Introduction

What is the “appropriate” notion of a functor between linearly (formerly “weakly”) distributive categories? In [CS92] we were content to think of the functors between linearly distributive categories as being those which preserved all the structure on the nose. However, this very restrictive notion does not allow the expression of common linear structure such as the exponentials

¹ Research partially supported by NSERC, Canada.

² Research partially supported by Le Fonds FCAR, Québec, and NSERC, Canada. Diagrams in this paper were produced with the help of the *TEXcad* drawing program of G. Horn and the *diagram* macros of F. Borceux.

and the additives. The purpose of this paper is to present, as a basis for expressing linear structure, a broader class of functors: the “linear functors” and their natural transformations.

Of course, one ought not to expect that all structure of interest in linear logic is described by linear functors. For example, in light linear logic [G95] the traditional exponential operators are no longer monoidal functors, as pointed out in [G95,KOS97], and so do not form a linear functor. Also, in full intuitionistic linear logic [HP93] the internal hom is not a linear functor. Nonetheless, it should be clear from this paper that the notion of a linear functor is a useful organizational device which does explain basic features of linear logic.

The notion of a linearly distributive category with the exponentials was explored in [BCS96]. In this paper we show that most of the coherence diagrams of [BCS96] are a consequence of demanding that the obvious functorial structure for exponentials be linear, *i.e.* constructed from linear functors and linear transformations. That the formulation of the exponentials should have such a simple genus is not only satisfying but is also a strong confirmation that the ideas underlying [BCS96] were correct.

In contrast to the situation for the exponentials, where a formulation already existed, we started this paper with little idea of what extra conditions might be required for the correct notion of additives (products and coproducts) in a linearly distributive setting. (Note that in a $*$ -autonomous setting there is little to worry about: the duality guarantees that if there are products, then there are also coproducts, and *vice versa*, and further, the closed structure guarantees the obvious distributivity for these.) In keeping with the thesis that linearity ought to guide one in adding structure to linearly distributive categories, we let the obvious linear functorial structure suggest the axiomatization. The result, which we discuss in the last section of the paper, is that this turns out to be equivalent to the much simpler structure of appropriately distributive products and coproducts. However, the linear structure is not without purpose: we shall develop a general circuit calculus for linear functors, using “functor boxes”. Although we do not discuss proof circuits for the additives in the present paper, it will be clear that the induced calculus in the case of the additives is equivalent to the additive proof boxes Girard used in his original description of proof nets for the additives.

Besides allowing the expression of the above structure, a *desiderata* for these linear functors is that, when specialized to the $*$ -autonomous case, they become an almost transparently simple notion. This in fact is the case: a linear functor between $*$ -autonomous categories is simply a monoidal functor: the additional linear structure is then forced by the setting. This allows one to rediscover linear functors by backward engineering the full structure implied by a monoidal functor between $*$ -autonomous categories.

Let \mathbf{X} and \mathbf{Y} be categories with involutions (for example $*$ -autonomous). Then any covariant functor $F: \mathbf{X} \rightarrow \mathbf{Y}$ induces a “complement” functor

$$\overline{F} = (F((-)^\perp))^\perp: \mathbf{X} \rightarrow \mathbf{Y}$$

and any natural transformation $\alpha_A: F(A) \rightarrow G(A)$ induces a natural “complement” transformation

$$\overline{\alpha}_A = \alpha_{A^\perp}^\perp: (G(A^\perp))^\perp \rightarrow (F(A^\perp))^\perp.$$

Thus, the morphisms between $*$ -autonomous categories are actually pairs of functors related by the complementation induced by the involution. But that is not all: if we demand that the first functor of the pair, say, is monoidal with respect to the tensor then, this will mean that the second functor is forced to be comonoidal with respect to the cotensor (or “par”). Furthermore, some peculiar transformations are introduced:

$$\nu: F(A \oplus B) \rightarrow \overline{F}(A) \oplus F(B)$$

and by complementation

$$\overline{\nu}: F(A) \otimes \overline{F}(B) \rightarrow \overline{F}(A \otimes B).$$

Essentially these are, respectively, a relative costrength and strength as described in [BCS96]. Our discussion of linear functors between linearly distributive categories can be viewed as an abstraction of these ideas.

The relationship between $*$ -autonomous categories and linearly distributive categories may be viewed as an abstraction of the relationship between Boolean algebras and distributive lattices. Just as any distributive lattice has a largest sublattice which is Boolean (obtained by considering the complemented elements) so a linearly distributive category has a largest full subcategory which is $*$ -autonomous (also consisting of complemented objects). This is called the “nucleus” of the linearly distributive category. The extraction of the nucleus is actually 2-functorial with respect to linear functors and transformations. In fact, the inclusion of the full sub2-category of $*$ -autonomous categories into the 2-category of linearly distributive categories with linear functors and transformations has a right bi-adjoint given by formation of the nucleus.

The ideas behind the formation of the nucleus are of some independent interest and have a considerable history. We include, therefore, a relatively self-contained appendix which describes the generalization of the work of Rowe [R88] and Higgs and Rowe [HR89] (which was done in the setting of monoidal closed categories) to linearly distributive categories. We also show that nuclear maps are preserved by linear functors.

The paper will have this structure: first we shall give the formal definition of a linearly distributive (or simply “linear”) functor of linearly distributive categories, together with the corresponding notion of linear transformation, so that the resulting structure is a 2–category LDC. Next we introduce a calculus of “functor boxes” which will allow us to use proof circuits to analyze the structure of linear (and monoidal) functors. Using this calculus of proof circuits, we show that any monoidal functor between $*$ -autonomous categories induces a linear functor. This holds in the noncommutative case as well, provided the functor is “well-behaved” with respect to the two negations present in that context. This means that there is an inclusion of the 2–category $*$ -AUT, of $*$ -autonomous categories and monoidal functors and transformations, into LDC. To construct a right bi-adjoint to this, we give the definition of nuclearity for linearly distributive categories and show that linear functors preserve the nucleus, that the nucleus is $*$ -autonomous (modulo some use of the axiom of choice), and that this gives the bi-adjunction discussed above.

Next we shall illustrate the conceptual advantage of this definition by showing that $!$ and $?$ may be described by saying that there is a linear cotriple on a linearly distributive category \mathbf{X} whose free coalgebras are comonoids. Finally, we shall apply these ideas to the matter of adding additive structure: requiring a linearly distributive category to have “products” (in the sense of an appropriate adjoint linear functor to the diagonal) will automatically endow the category with cartesian products and coproducts, which satisfy the obvious distributivity laws with respect to tensor and par.

A word about terminology and notation. The reader will have already noticed that we have adopted the term “linearly distributive category” for what previously we have called “weakly distributive category”, continuing the practice begun in [CS97]. This we view as a minor matter. More controversial perhaps is our insistence upon the use of \otimes for “par” and \oplus for the coproduct “sum”. As category theorists we are unrepentant upon this point, and there the matter must rest.

1 Linear functors

For the full definition of a linearly distributive category, we refer the reader to [CS92,CS92j,BCST] (where the term “weakly distributive category” is used). Briefly, a linearly distributive category is a category with two tensors \otimes, \oplus and two strength natural transformations, making each strong (respectively costrong) with respect to the other. These two strength transformations shall

be denoted by:

$$\begin{aligned}\delta_L^L &: A \otimes (B \oplus C) \rightarrow (A \otimes B) \oplus C \\ \delta_R^R &: (B \oplus C) \otimes A \rightarrow B \oplus (C \otimes A).\end{aligned}$$

A symmetric linearly distributive category is a linearly distributive category both of whose tensors are symmetric. In this case there are these additional induced strength transformations:

$$\begin{aligned}\delta_R^L &: A \otimes (B \oplus C) \rightarrow B \oplus (A \otimes C) \\ \delta_L^R &: (B \oplus C) \otimes A \rightarrow (B \otimes A) \oplus C.\end{aligned}$$

This data must satisfy standard coherence conditions, discussed in [CS92], which we shall not repeat here.

Also, recall that for a functor F to be monoidal there must be natural transformations $m_\otimes: F(A) \otimes F(B) \rightarrow F(A \otimes B)$ and $m_\top: \top \rightarrow F(\top)$ satisfying the equations

$$\begin{aligned}u_\otimes &= m_\top \otimes 1; m_\otimes; F(u_\otimes) \\ &: \top \otimes F(A) \rightarrow F(A)\end{aligned}\tag{1}$$

$$\begin{aligned}a_\otimes; 1 \otimes m_\otimes; m_\otimes &= m_\otimes \otimes 1; m_\otimes; F(a_\otimes) \\ &: (F(A) \otimes F(B)) \otimes F(C) \rightarrow F(A \otimes (B \otimes C))\end{aligned}\tag{2}$$

(and in the symmetric case, the next equation as well.)

$$m_\otimes; F(c_\otimes) = c_\otimes; m_\otimes: F(A) \otimes F(B) \rightarrow F(B \otimes A)\tag{3}$$

For a functor G to be comonoidal, there must be natural transformations $n_\oplus: G(A \oplus B) \rightarrow G(A) \oplus G(B)$ and $n_\perp: G(\perp) \rightarrow \perp$ satisfying equations dual to those above.

Next we introduce a notion of functor between linearly distributive categories; these ought to be called “linearly distributive functors”, but we have preferred the shorter “linear functor”.

Definition 1 *Given linearly distributive categories \mathbf{X} , \mathbf{Y} , a linear functor $F: \mathbf{X} \rightarrow \mathbf{Y}$ consists of:*

- (i) *a pair of functors $F_\otimes, F_\oplus: \mathbf{X} \rightarrow \mathbf{Y}$ so that F_\otimes is monoidal with respect to \otimes , and F_\oplus is comonoidal with respect to \oplus ,*

(ii) natural transformations (called “linear strengths”)

$$\begin{aligned}\nu_{\otimes}^R &: F_{\otimes}(A \oplus B) \rightarrow F_{\oplus}(A) \oplus F_{\otimes}(B) \\ \nu_{\otimes}^L &: F_{\otimes}(A \oplus B) \rightarrow F_{\otimes}(A) \oplus F_{\oplus}(B) \\ \nu_{\oplus}^R &: F_{\otimes}(A) \otimes F_{\oplus}(B) \rightarrow F_{\oplus}(A \otimes B) \\ \nu_{\oplus}^L &: F_{\oplus}(A) \otimes F_{\otimes}(B) \rightarrow F_{\oplus}(A \otimes B)\end{aligned}$$

satisfying the following coherence conditions. (These are listed in groups given by the evident dualities. In each group we illustrate one with a commutative diagram; only the equations corresponding to these diagrams are numbered.)

$$\begin{array}{ccc} F_{\otimes}(\perp \oplus A) & \xrightarrow{F_{\otimes}(u_{\oplus}^L)} & F_{\otimes}(A) \\ \nu_{\otimes}^R \downarrow & & \uparrow u_{\oplus}^L \\ F_{\oplus}(\perp) \oplus F_{\otimes}(A) & \xrightarrow{n_{\perp} \oplus 1} & \perp \oplus F_{\otimes}(A) \end{array}$$

$$\begin{aligned}\nu_{\otimes}^R; n_{\perp} \oplus 1; u_{\oplus}^L &= F_{\otimes}(u_{\oplus}^L) \\ \nu_{\otimes}^L; 1 \oplus n_{\perp}; u_{\oplus}^R &= F_{\otimes}(u_{\oplus}^R) \\ u_{\otimes}^{L^{-1}}; m_{\top} \otimes 1; \nu_{\oplus}^R &= F_{\oplus}(u_{\otimes}^{L^{-1}}) \\ u_{\otimes}^{R^{-1}}; 1 \otimes m_{\top}; \nu_{\oplus}^L &= F_{\oplus}(u_{\otimes}^{R^{-1}})\end{aligned} \tag{4}$$

$$\begin{array}{ccc} F_{\otimes}((A \oplus B) \oplus C) & \xrightarrow{F_{\otimes}(a_{\oplus})} & F_{\otimes}(A \oplus (B \oplus C)) \\ \nu_{\otimes}^R \downarrow & & \downarrow \nu_{\otimes}^R \\ F_{\oplus}(A \oplus B) \oplus F_{\otimes}(C) & & F_{\oplus}(A) \oplus F_{\otimes}(B \oplus C) \\ n_{\oplus} \oplus 1 \downarrow & & \downarrow 1 \oplus \nu_{\otimes}^R \\ (F_{\oplus}(A) \oplus F_{\oplus}(B)) \oplus F_{\otimes}(C) & \xrightarrow{a_{\oplus}} & F_{\oplus}(A) \oplus (F_{\oplus}(B) \oplus F_{\otimes}(C)) \end{array}$$

$$\begin{aligned}F_{\otimes}(a_{\oplus}); \nu_{\otimes}^R; 1 \otimes \nu_{\otimes}^R &= \nu_{\otimes}^R; n_{\oplus} \oplus 1; a_{\oplus} \\ F_{\otimes}(a_{\oplus}); \nu_{\otimes}^L; 1 \oplus n_{\oplus} &= \nu_{\otimes}^L; \nu_{\otimes}^L \oplus 1; a_{\oplus} \\ m_{\otimes} \otimes 1; \nu_{\oplus}^R; F_{\oplus}(a_{\otimes}) &= a_{\otimes}; 1 \otimes \nu_{\oplus}^R; \nu_{\oplus}^R \\ \nu_{\oplus}^L \otimes 1; \nu_{\oplus}^L; F_{\oplus}(a_{\otimes}) &= a_{\otimes}; 1 \otimes m_{\otimes}; \nu_{\oplus}^L\end{aligned} \tag{5}$$

$$\begin{array}{ccc}
F_{\otimes}((A \oplus B) \oplus C) & \xrightarrow{F_{\otimes}(a_{\oplus})} & F_{\otimes}(A \oplus (B \oplus C)) \\
\nu_{\otimes}^L \downarrow & & \downarrow \nu_{\otimes}^R \\
F_{\otimes}(A \oplus B) \oplus F_{\oplus}(C) & & F_{\oplus}(A) \oplus F_{\otimes}(B \oplus C) \\
\nu_{\otimes}^R \oplus 1 \downarrow & & \downarrow 1 \oplus \nu_{\otimes}^L \\
(F_{\oplus}(A) \oplus F_{\otimes}(B)) \oplus F_{\oplus}(C) & \xrightarrow{a_{\oplus}} & F_{\oplus}(A) \oplus (F_{\otimes}(B) \oplus F_{\oplus}(C))
\end{array}$$

$$\begin{aligned}
& F_{\otimes}(a_{\oplus}); \nu_{\otimes}^R; 1 \otimes \nu_{\otimes}^L = \nu_{\otimes}^L; \nu_{\otimes}^R \oplus 1; a_{\oplus} \\
& \nu_{\oplus}^R \otimes 1; \nu_{\oplus}^L; F_{\oplus}(a_{\otimes}) = a_{\otimes}; 1 \otimes \nu_{\oplus}^L; \nu_{\oplus}^R
\end{aligned} \tag{6}$$

$$\begin{array}{ccc}
F_{\otimes}(A) \otimes F_{\otimes}(B \oplus C) & \xrightarrow{1 \otimes \nu_{\otimes}^R} & F_{\otimes}(A) \otimes (F_{\oplus}(B) \oplus F_{\otimes}(C)) \\
m_{\otimes} \downarrow & & \downarrow \delta_L^L \\
F_{\otimes}(A \otimes (B \oplus C)) & & (F_{\otimes}(A) \otimes F_{\oplus}(B)) \oplus F_{\otimes}(C) \\
F_{\otimes}(\delta_L^L) \downarrow & & \downarrow \nu_{\oplus}^R \oplus 1 \\
F_{\otimes}((A \otimes B) \oplus C) & \xrightarrow{\nu_{\otimes}^R} & F_{\oplus}(A \otimes B) \oplus F_{\otimes}(C)
\end{array}$$

$$\begin{aligned}
& 1 \otimes \nu_{\otimes}^R; \delta_L^L; \nu_{\oplus}^R \oplus 1 = m_{\otimes}; F_{\otimes}(\delta_L^L); \nu_{\otimes}^R \\
& \nu_{\otimes}^L \otimes 1; \delta_R^R; 1 \oplus \nu_{\oplus}^L = m_{\otimes}; F_{\otimes}(\delta_R^R); \nu_{\otimes}^L \\
& 1 \otimes \nu_{\otimes}^L; \delta_L^L; \nu_{\oplus}^L \oplus 1 = \nu_{\oplus}^L; F_{\oplus}(\delta_L^L); n_{\oplus} \\
& \nu_{\otimes}^R \otimes 1; \delta_R^R; 1 \oplus \nu_{\oplus}^R = \nu_{\oplus}^R; F_{\oplus}(\delta_R^R); n_{\oplus}
\end{aligned} \tag{7}$$

$$\begin{array}{ccc}
F_{\otimes}(A) \otimes F_{\otimes}(B \oplus C) & \xrightarrow{1 \otimes \nu_{\otimes}^L} & F_{\otimes}(A) \otimes (F_{\otimes}(B) \oplus F_{\oplus}(C)) \\
m_{\otimes} \downarrow & & \downarrow \delta_L^L \\
F_{\otimes}(A \otimes (B \oplus C)) & & (F_{\otimes}(A) \otimes F_{\otimes}(B)) \oplus F_{\oplus}(C) \\
F_{\otimes}(\delta_L^L) \downarrow & & \downarrow m_{\otimes} \oplus 1 \\
F_{\otimes}((A \otimes B) \oplus C) & \xrightarrow{\nu_{\otimes}^L} & F_{\otimes}(A \otimes B) \oplus F_{\oplus}(C)
\end{array}$$

$$\begin{aligned}
& 1 \otimes \nu_{\otimes}^L; \delta_L^L; m_{\otimes} \oplus 1 = m_{\otimes}; F_{\otimes}(\delta_L^L); \nu_{\otimes}^L \\
& \nu_{\otimes}^R \otimes 1; \delta_R^R; 1 \oplus m_{\otimes} = m_{\otimes}; F_{\otimes}(\delta_R^R); \nu_{\otimes}^R
\end{aligned} \tag{8}$$

$$1 \otimes n_{\oplus}; \delta_L^L; \nu_{\oplus}^R \oplus 1 = \nu_{\oplus}^R; F_{\oplus}(\delta_L^L); n_{\oplus}$$

$$n_{\oplus} \otimes 1; \delta_R^R; 1 \oplus \nu_{\oplus}^L = \nu_{\oplus}^L; F_{\oplus}(\delta_R^R); n_{\oplus}$$

Remark 2 In the commutative case, it is possible to drop the requirement that the ν^L 's exist, defining them *via* the symmetry of the tensor and par. Equivalently, we could keep the presentation above and add the extra diagrams that express such definition, namely $\nu_{\otimes}^R; c_{\otimes} = F_{\otimes}(c_{\otimes}); \nu_{\otimes}^L$, and its dual.

Next, we address the question of the appropriate notion of natural transformation. Following the ideas outlined in the Introduction, we are led to the following definition. Recall that for a natural transformation α to be monoidal, the following equations must be satisfied.

$$m_{\otimes}; \alpha = \alpha \otimes \alpha; m_{\otimes} : F(A) \otimes F(B) \rightarrow G(A \otimes B) \quad (9)$$

$$m_{\otimes}; \alpha = m_{\otimes} : \top \rightarrow G(\top) \quad (10)$$

A comonoidal natural transformation must satisfy the dual conditions.

Definition 3 Given $F, G: \mathbf{X} \rightarrow \mathbf{Y}$, linear functors between linearly distributive categories, a linear transformation $\alpha: F \rightarrow G$ consists of a pair of natural transformations: a monoidal transformation $\alpha_{\otimes}: F_{\otimes} \rightarrow G_{\otimes}$ and a comonoidal transformation $\alpha_{\oplus}: G_{\oplus} \rightarrow F_{\oplus}$. These must satisfy the following coherence conditions.

$$\begin{array}{ccc}
 F_{\otimes}(A \oplus B) & \xrightarrow{\alpha_{\otimes}} & G_{\otimes}(A \oplus B) \\
 \nu_{\otimes}^R \downarrow & & \downarrow \nu_{\otimes}^R \\
 F_{\oplus}(A) \oplus F_{\otimes}(B) & & G_{\oplus}(A) \oplus G_{\otimes}(B) \\
 \searrow 1 \oplus \alpha_{\otimes} & & \swarrow \alpha_{\oplus} \oplus 1 \\
 & F_{\oplus}(A) \oplus G_{\otimes}(B) &
 \end{array}$$

$$\alpha_{\otimes}; \nu_{\otimes}^R; \alpha_{\oplus} \oplus 1 = \nu_{\otimes}^R; 1 \oplus \alpha_{\otimes} \quad (11)$$

$$\alpha_{\otimes}; \nu_{\otimes}^L; 1 \oplus \alpha_{\oplus} = \nu_{\otimes}^L; \alpha_{\otimes} \oplus 1$$

$$1 \otimes \alpha_{\otimes}; \nu_{\oplus}^L; \alpha_{\oplus} = \alpha_{\oplus} \otimes 1; \nu_{\oplus}^L$$

$$\alpha_{\otimes} \otimes 1; \nu_{\oplus}^R; \alpha_{\oplus} = 1 \otimes \alpha_{\oplus}; \nu_{\oplus}^R$$

Proposition 4 Linearly distributive categories, linear functors, and linear transformations form a 2-category, which we shall denote LDC. If we restrict to symmetric linearly distributive categories, we obtain a 2-category denoted SLDC. These 2-categories are closed under products.

Proof. Identity maps are the standard identity functors and transformations. (These are obviously linear.) Linear functors compose in the obvious way: $(F;G)_\otimes = F_\otimes;G_\otimes$ and $(F;G)_\oplus = F_\oplus;G_\oplus$. The strength ${}^{F;G}\nu_\otimes^R$ is defined as ${}^{F;G}\nu_\otimes^R = G_\otimes({}^F\nu_\otimes^R);{}^G\nu_\otimes^R$; the other linear strengths are defined similarly. (Here ${}^F\nu_\otimes^R$ indicates the ν for the functor F , and so forth.)

For transformations, we have two types of composition. If $F, G, H: \mathbf{X} \rightarrow \mathbf{Y}$, $\alpha: F \rightarrow G$ and $\beta: G \rightarrow H$, then $(\alpha; \beta)_\otimes = \alpha_\otimes; \beta_\otimes$ and $(\alpha; \beta)_\oplus = \beta_\oplus; \alpha_\oplus$. If $F, G: \mathbf{X} \rightarrow \mathbf{Y}$, $H, K: \mathbf{Y} \rightarrow \mathbf{Z}$, $\alpha: F \rightarrow G$, and $\beta: H \rightarrow K$, then $(\alpha; \beta)_\otimes = \beta_\otimes; K(\alpha_\otimes)$ and $(\alpha; \beta)_\oplus = K(\alpha_\oplus); \beta_\oplus$. (We have used the same symbol for both vertical and horizontal composition of transformations—the context ought to make clear which is intended at any time.) Note that naturality implies that $\beta_\otimes; K_\otimes(\alpha_\otimes) = H_\otimes(\alpha_\otimes); \beta_\otimes$, (and similarly for the \oplus case), so this gives an alternate definition; this also guarantees the validity of the interchange law.

$$\begin{array}{ccc}
 H_\otimes(F_\otimes(A)) & \xrightarrow{\beta_\otimes} & K_\otimes(F_\otimes(A)) \\
 H_\otimes(\alpha_\otimes) \downarrow & & \downarrow K_\otimes(\alpha_\otimes) \\
 H_\otimes(G_\otimes(A)) & \xrightarrow{\beta_\otimes} & K_\otimes(G_\otimes(A))
 \end{array}$$

Now there are several coherence conditions to check here. Three of the diagrams needed for $F;G$ are given in Figure 1; we omit two as they are very similar to other diagrams. The diagrams for vertical and horizontal composition of transformations are given in Figure 2. The cells marked (lin) commute by the corresponding coherence condition on $F, G, \alpha, \beta, \dots$, as appropriate. The cells marked (nat) commute by naturality. Note that in these Figures, we have abbreviated the functors and transformations using the notation $F_\otimes = F$, $F_\oplus = \hat{F}$, and so forth, in order to save space. Using appropriate duality, this completes the proof that these form 2-categories. As for closure under products, that is quite trivial (the monoidal and comonoidal components are constructed pointwise), and shall be left to the reader. \square

2 Circuits for linear functors

In [BCST] we developed a calculus of graph rewrites for proof nets (“circuits”) for linearly distributive categories; in the present note we shall extend that system to be able to handle functors as well. We shall be most interested in linear functors, but on the way we shall see how ordinary functors and how monoidal (and dually comonoidal) functors may be dealt with as well.

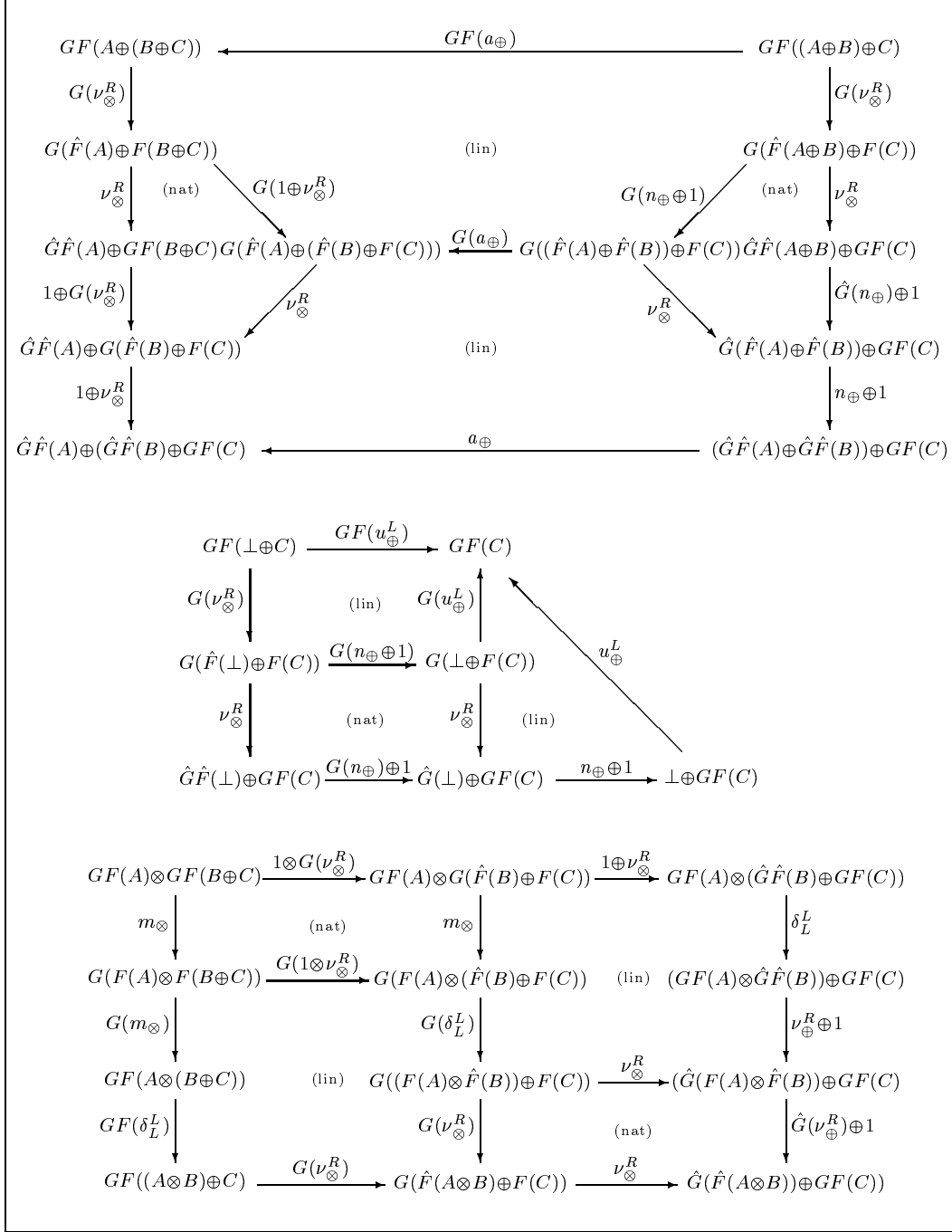

Fig. 1. Coherence for $F; G$

This treatment of functors is very closely related to the calculus we developed in [BCS96] to handle $!$ and $?$, and in a sense was almost implicit in that paper. There are some differences, and it may be instructive to imagine treating $!$ and $?$ in the present manner, taking functor boxes as primitive instead of the traditional storage boxes used in that paper.

To begin with, we suppose $F: \mathbf{X} \rightarrow \mathbf{Y}$ is a functor between linearly distributive

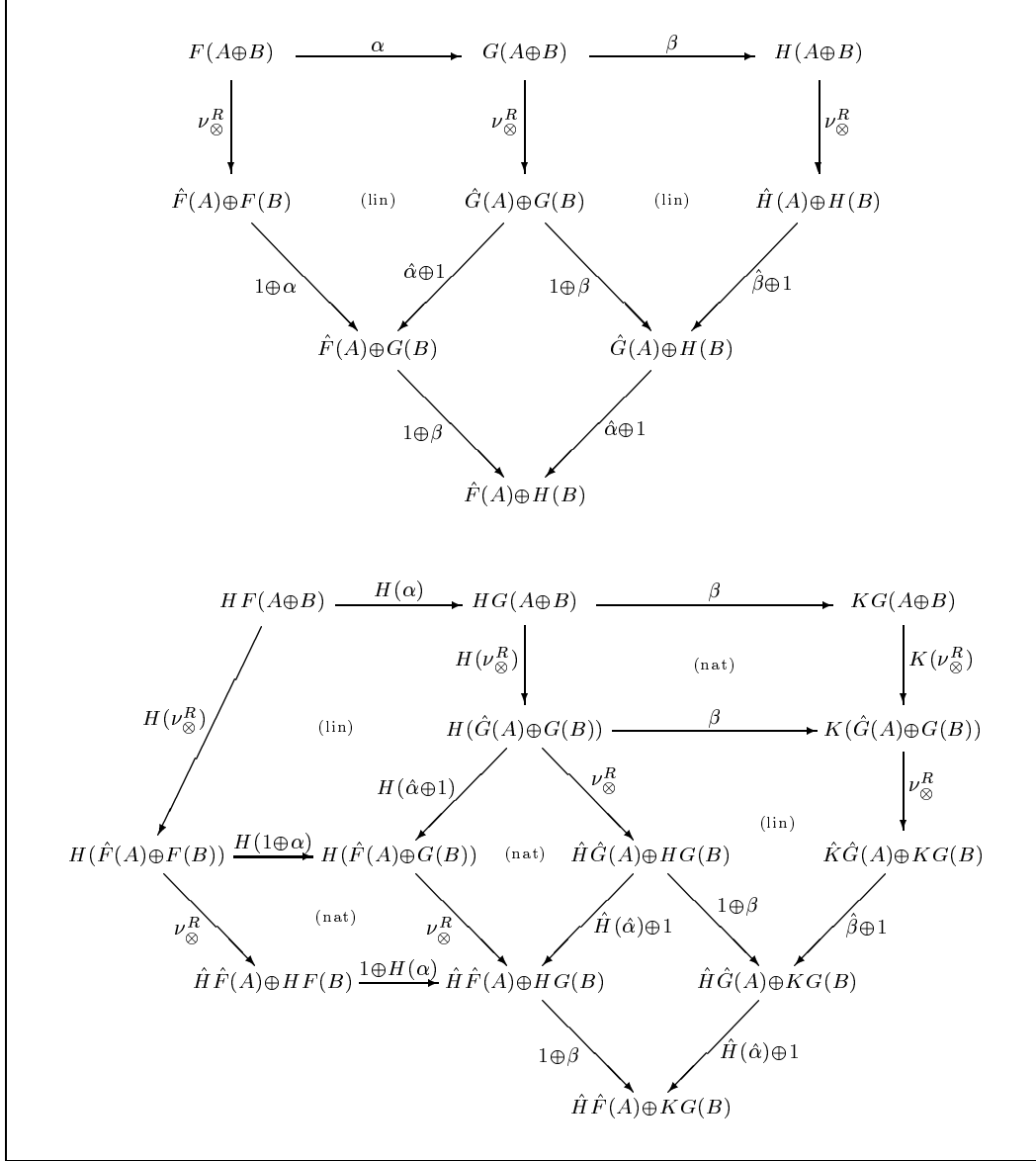

Fig. 2. Coherence for $\alpha; \beta$ — vertical and horizontal

categories. To be able to handle this with proof nets, we suppose that there is a “box-construction” on the nets for \mathbf{Y} which takes a subnet f in \mathbf{X} and produces a component for \mathbf{Y} . This component is represented as box which contains the net f . Sequentialization proceeds by first checking that f sequentializes and then treating the boxed f as a component in the larger net. These functor boxes are represented graphically as shown in Figure 3 on the left. Note that the box bears a label with the name of the functor. These functor boxes have one input and one output; if the net f has more, then appropriate use of tensor and par links must be made before the functor box is applied. (We shall relax this condition soon in discussing monoidal and linear functors.) The half oval through which the wire leaves the box is called the “principle port”; its role will become clear later. Notice also the typing changes the box imposes on a

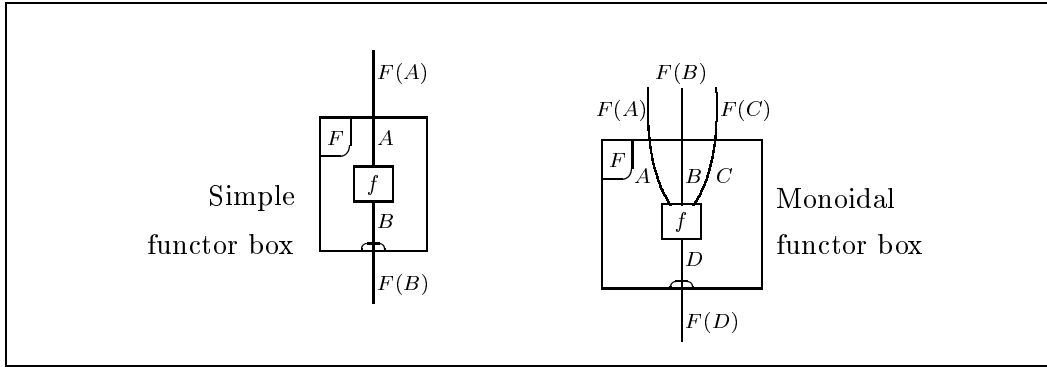

Fig. 3. Functor boxes

wire as it passes into or out of a box.

There are two obvious rewrites: an “expansion” which takes an identity wire of type $F(A)$ and replaces it with an identity wire of type A which is then “boxed”, and a “reduction” which “merges” two functor boxes one of which directly “feeds” into the next. As we shall see a generalization of this soon, we shall leave the picture to the reader.

If we suppose that the functor F is monoidal, then we can get a more interesting situation, for then we may relax the supposition that the boxed subgraph is “one-in-one-out” to allow multi-maps, or subgraphs that have many input wires (but still just one output wire). Then the box rule looks like the circuit in Figure 3 on the right, (where we take three as a generic number of inputs for simplicity).

One might expect that we would have to add components representing the two natural transformations m_{\otimes}, m_{\top} that are necessary for F to be monoidal. However, it is an easy exercise to show that these can be induced by the formation rule for monoidal functor boxes: m_{\otimes} is the case where f is the $(\otimes I)$ node (two inputs, A, B and one output $A \otimes B$), and m_{\top} is the case where f is the $(\top I)$ node (no inputs and one output \top).

The necessary reduction rewrite is shown in Figure 4 (we refer to this saying one box “eats” the other).

In addition, we have the “expansion” rule mentioned before, and in the symmetric case we also need a rewrite that allows a “twist” to be brought outside a box. These are shown in Figure 5

For a functor F to be monoidal, recall there must be natural transformations $m_{\otimes}: F(A) \otimes F(B) \rightarrow F(A \otimes B)$ and $m_{\top}: \top \rightarrow F(\top)$ satisfying certain equations (as in Remark 2). We have already indicated what the nets are for m_{\otimes}, m_{\top} . It is fairly straightforward to show that the equations are consequences of the net rewrites given above, and that the rewrites correspond to

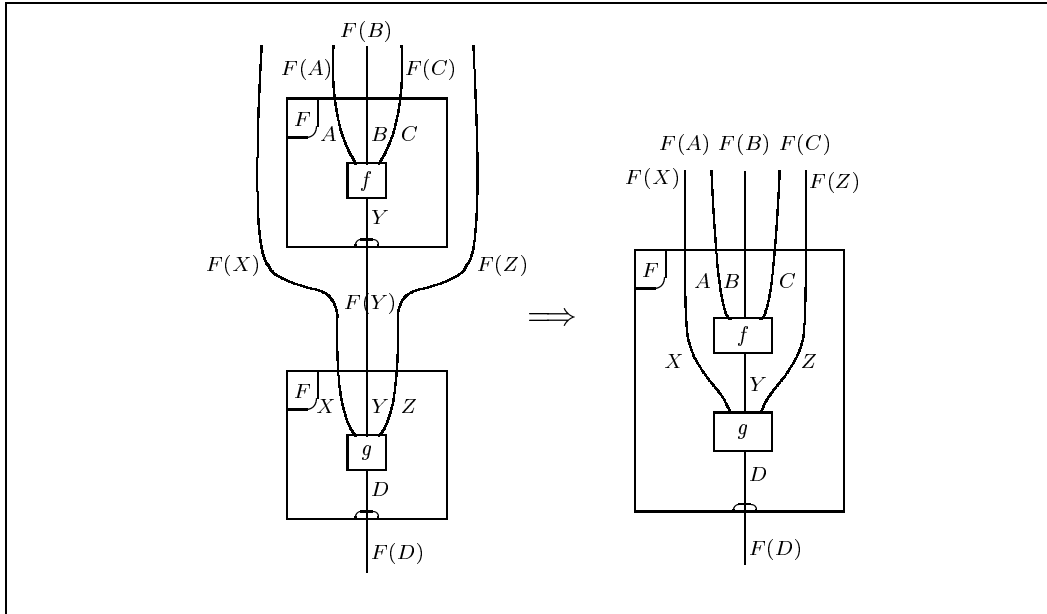

Fig. 4. Box-eats-box rule

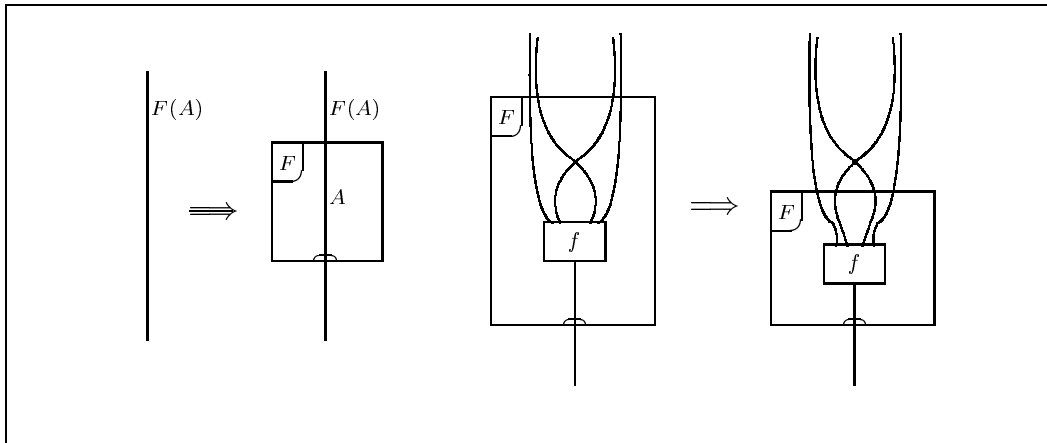

Fig. 5. Expansion and twist rules

commutative diagrams, if F is monoidal. For example, in Figure 6 we show that equation (2) for monoidal functors, dealing with “reassociation”, is true for any F whose functor boxes satisfy the circuit rewrites we have given so far. The others are similar. So this circuit syntax is indeed sound and complete for monoidal functors. For comonoidal functors, we just use a dual syntax, with the corresponding rewrites. Note then that for comonoidal functors, the principle port will be at the top of the box (this is the role of the principle port, to distinguish monoidal functors from comonoidal ones).

Finally, we extend the syntax of functor boxes to linear functors; in this case we find that all that is necessary is to generalize the preceding to allow the boxed subnet to have arbitrarily many inputs and outputs. So for the monoidal component F_{\otimes} of a linear functor F , the functor boxes will have the formation rule shown in Figure 7, and the comonoidal component will have the dual rule

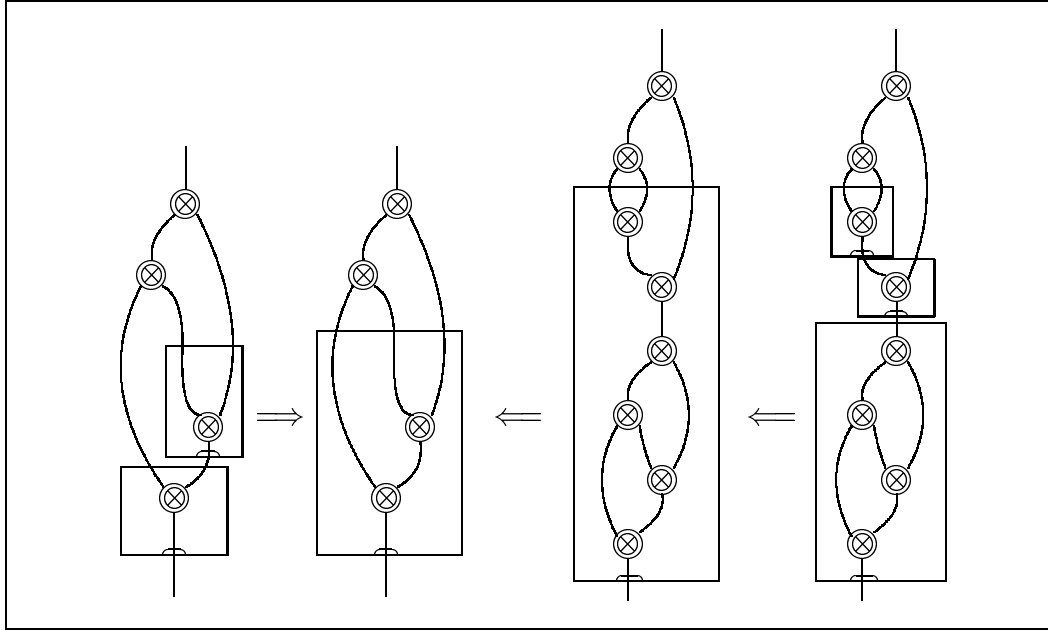

Fig. 6. Functor boxes are monoidal—equation (2)

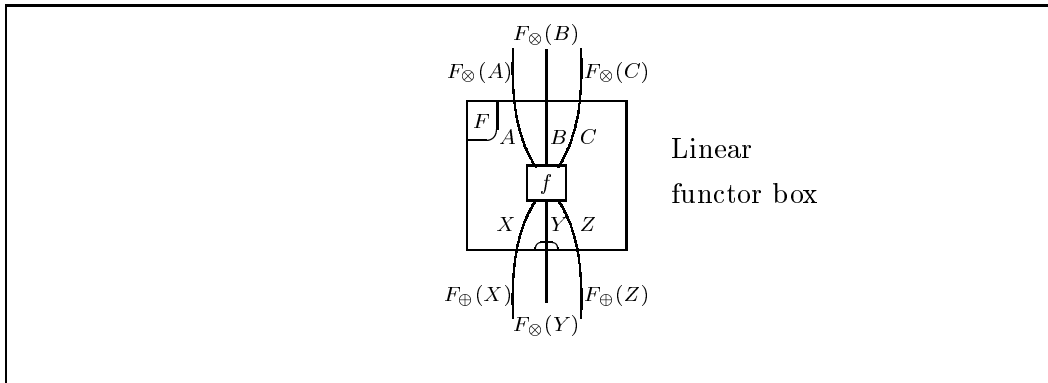

Fig. 7. Linear functor box

(just turn the page upside down). Please note the typing of this formation rule carefully: at the top of the box, the functor applied is the functor F_\otimes associated with the box, but at the bottom, only the wire that leaves through the principal port gets an F_\otimes attached to it, the other wires get the comonoidal F_\oplus attached to them. (The dual situation applies for the F_\oplus boxes.) This is the role of the principal port in our notation (and is similar to the notation used in [BCS96]). There may be only one principal port, though there may be arbitrarily many other (“auxiliary”) ports.

As suggested, it is then quite easy to represent the ν_\otimes^R map as a boxed $(\oplus E)$ node—the right output wire of the node passes through the principal port. The three other linear strengths are given similarly: ν_\otimes^L is the $(\oplus E)$ node boxed with a F_\otimes box, the left output wire passing through the principal port. The two ν_\oplus maps are given by the $(\otimes I)$ node boxed by the F_\oplus box, with either the right or the left input ports being the principal port, as appropriate.

Associated with these box formation rules are several rewrites. The expansion rewrite remains as before, but the reduction rewrite must be generalized to account for the more general f ; this is done in the obvious fashion. Similarly, in the symmetric case we generalize the rewrites that move a “twist” outside a box; in fact, in the symmetric case it is convenient to regard the order of inputs/outputs as irrelevant (as we did in [BCST]), so that these rewrites are in fact equalities of circuits. In addition, we must account for the interaction between F_{\otimes} and F_{\oplus} boxes, which gives a series of rewrites that allow one box to “eat” another whenever a non-principal wire of one type of box becomes the principal wire of the dual type. We give an example of this in Table 1, along with the other rules mentioned in this paragraph. The reader may generate the dual rules. Note that in this Table we have illustrated circuits with crossings of wires; in the noncommutative case, such crossings must not occur, so some wires must be absent from these rewrites. The rewrites dealing with pulling a “twist” out of a box are only relevant in the symmetric case of course. We have illustrated one, where the “twisted” wires are inputs; it is also possible that the “twisted” wires are outputs, and one may (or may not) be the wire through the principle port.

To verify the soundness and completeness of these rules, we must verify that any $F = (F_{\otimes}, F_{\oplus})$ which allows such a calculus is indeed a linear functor, and conversely, that any linear functor allows such rewrites. The former is fairly straightforward, involving the reduction of a number of circuits, similar to the rewrites in Figure 6 for monoidal functors. As for the latter, we must verify first the existence of maps corresponding to the box formation rules, and secondly, the commutativity of diagrams corresponding to the circuit rewrites. To illustrate the first, suppose for example that $f: (A \otimes B) \otimes C \rightarrow (X \oplus Y) \oplus Z$, then we can derive the “boxed” map as follows.

$$\begin{aligned}
(F_{\otimes}(A) \otimes F_{\otimes}(B)) \otimes F_{\otimes}(C) &\xrightarrow{m \otimes 1; m} F_{\otimes}((A \otimes B) \otimes C) \\
&\xrightarrow{F_{\otimes}(f)} F_{\otimes}((X \oplus Y) \oplus Z) \\
&\xrightarrow{\nu_{\otimes}^L} F_{\otimes}(X \oplus Y) \oplus F_{\oplus}(Z) \\
&\xrightarrow{\nu_{\otimes}^R \oplus 1} (F_{\oplus}(X) \oplus F_{\otimes}(Y)) \oplus F_{\oplus}(Z)
\end{aligned}$$

The reader can see how using m and n (just as we did at the start of the derivation above) this may be extended to accommodate any number of auxiliary ports.

As an illustration of a commutative diagram corresponding to one of the rewrites, consider the rewrite where a monoidal box eats a comonoidal one, when an auxiliary wire of the former becomes the principal wire of the latter. To be specific, suppose each box has two input and two output wires, corre-

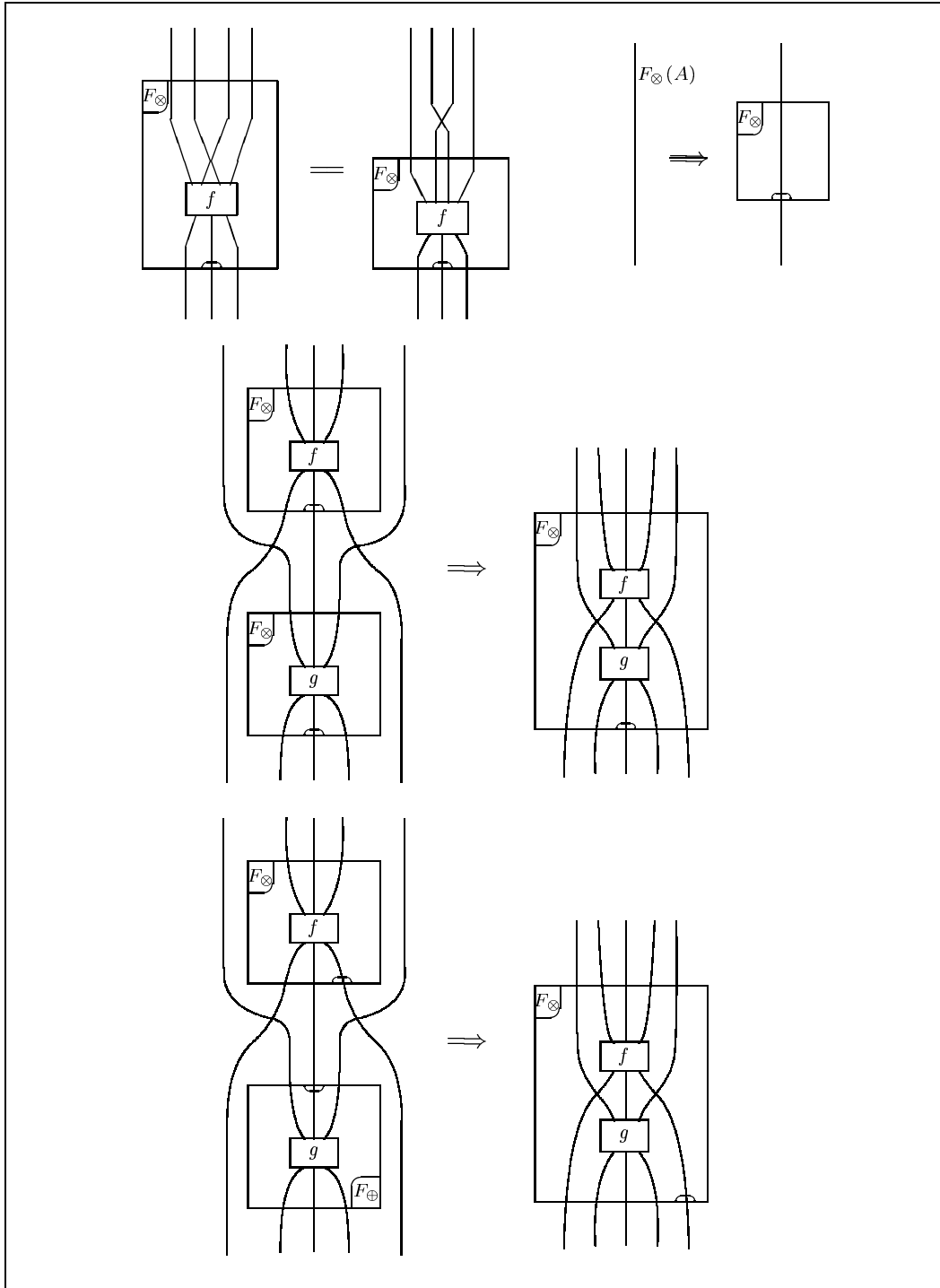

Table 1

Some reduction and expansion rewrites for functor boxes

sponding to maps $f: B \otimes C \rightarrow D \oplus Z$ and $g: A \otimes D \rightarrow X \oplus Y$. The circuit consisting of the two boxes cut together is the left–lower path in the diagram in Figure 8, and the circuit obtained when the boxes merge is the top–right path. The commutativity is shown by the decomposition. The other rewrites are treated similarly.

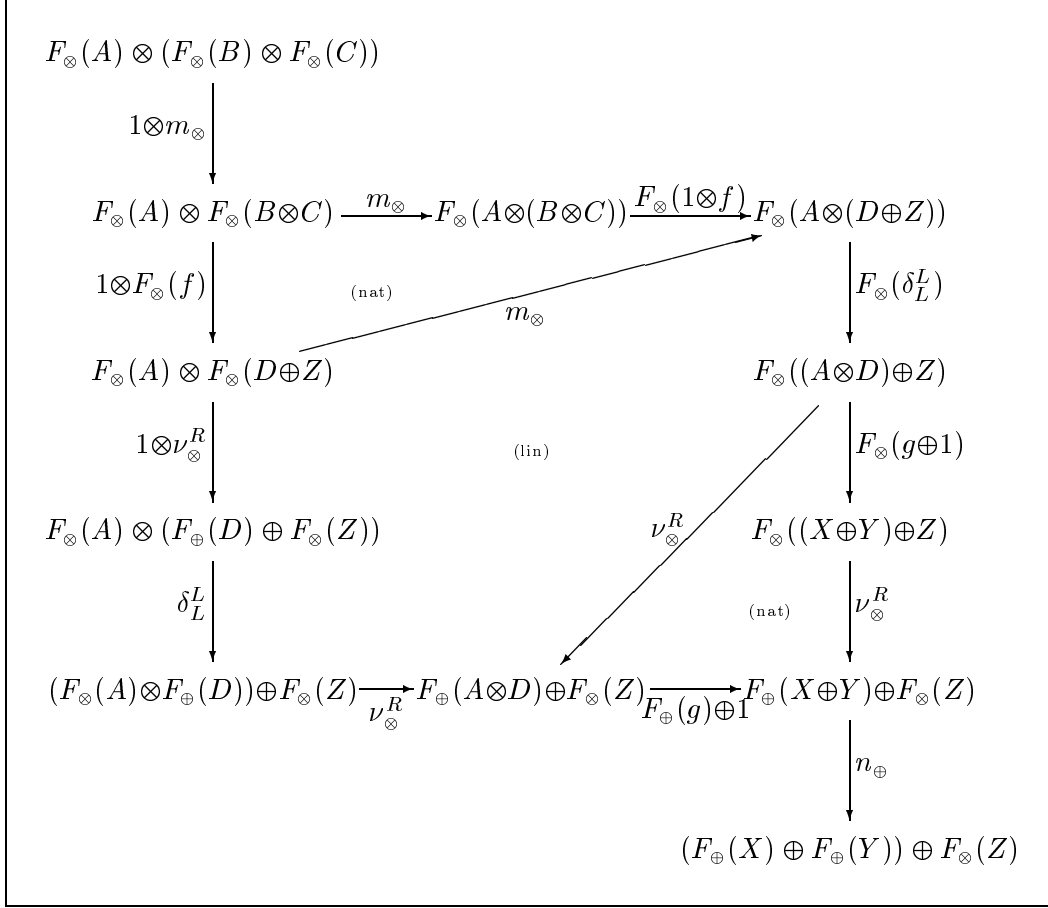

Fig. 8. Validity of one of the box rewrite rules

$\begin{array}{c} | \\ F(A) \\ \boxed{\alpha} \\ | \\ G(A) \end{array}$
 Next we consider linear transformations. Given $\alpha: F \rightarrow G: \mathbf{X} \rightarrow \mathbf{Y}$, for an object A of \mathbf{X} there is a morphism $\alpha_A: F(A) \rightarrow G(A)$, which would be represented as a node in a circuit. We shall use the notation at left, which suppresses reference to the object A . To guarantee this is a natural transformation we need some rewrites, which we shall leave to the reader, as our first step will be to generalize them to the case when α is monoidal, and then linear. In fact, it is sufficient to give the rewrites for linear transformations, since restricting them to the monoidal syntax will give the appropriate rewrites for that case, and indeed, restricting to the “one-in-one-out” general case will give the rewrites for naturality. So let us suppose $\alpha = (\alpha_{\otimes}, \alpha_{\oplus})$ is a linear transformation; then the rewrite of Figure 9 is an equivalence, as is the dual one for α_{\oplus} , (and of course variants with other numbers of auxiliary ports). We shall leave to the reader the simple exercise of verifying that this characterizes linear transformations.

We can now use this graphical representation to show that a monoidal functor between $*$ -autonomous categories induces a linear functor between those categories, and similarly that a monoidal transformation between monoidal functors induces a linear transformation between the induced linear functors.

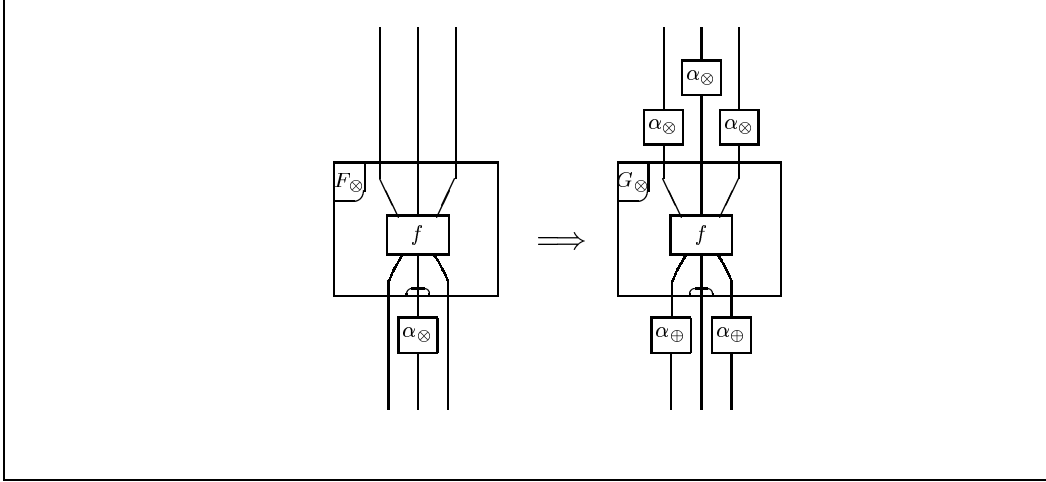

Fig. 9. Rewrite rule for linear transformations

In short, the inclusion of $*$ -autonomous categories into the category of linearly distributive categories extends to an inclusion of 2-categories.

Suppose \mathbf{X} , \mathbf{Y} are symmetric $*$ -autonomous categories, $F: \mathbf{X} \rightarrow \mathbf{Y}$ a monoidal functor. Then F induces a linear functor in the manner described in the introduction: $F_{\otimes} = F$, $F_{\oplus} = (F((-)^{\perp}))^{\perp}$.

In the noncommutative case, where there are two negations defined in \mathbf{X} , \mathbf{Y} , we can define F_{\oplus} if F satisfies, in addition, that ${}^{\perp}(F(A^{\perp})) = (F({}^{\perp}A))^{\perp}$, in which case $F_{\oplus}(A)$ is this common value. We can relax this condition somewhat, only requiring a natural isomorphism instead of equality, at the extra expense of explicitly keeping track of this isomorphism. For the moment, however, we shall not make this additional generalization in order to keep things simple.

We have to define $\nu_{\otimes}^R: F_{\otimes}(A \oplus B) \rightarrow F_{\oplus}(A) \oplus F_{\otimes}(B)$, which in this case becomes

$$\begin{aligned}
\nu_{\otimes}^R: F(A \oplus B) &\xrightarrow{u_{\otimes}^L} \top \otimes F(A \oplus B) \\
&\xrightarrow{\tau \otimes 1} (F({}^{\perp}A)^{\perp} \oplus F({}^{\perp}A)) \otimes F(A \oplus B) \\
&\xrightarrow{\delta_R^R} F({}^{\perp}A)^{\perp} \oplus (F({}^{\perp}A)) \otimes F(A \oplus B) \\
&\xrightarrow{1 \oplus m_{\otimes}} F({}^{\perp}A)^{\perp} \oplus F({}^{\perp}A \otimes (A \oplus B)) \\
&\xrightarrow{1 \oplus F(\delta_L^L)} F({}^{\perp}A)^{\perp} \oplus F(({}^{\perp}A \otimes A) \oplus B) \\
&\xrightarrow{1 \oplus F(\gamma \oplus 1)} F({}^{\perp}A)^{\perp} \oplus F({}^{\perp} \oplus B) \\
&\xrightarrow{1 \oplus u_{\oplus}^L} F({}^{\perp}A)^{\perp} \oplus F(B)
\end{aligned}$$

The other linear strengths are similarly defined.

Next, if we are given a monoidal natural transformation α between monoidal functors F, G between $*$ -autonomous categories, we can define a linear transformation $\alpha = (\alpha_{\otimes}, \alpha_{\oplus})$, where $\alpha_{\otimes} = \alpha$ and $(\alpha_{\oplus})_A = (\alpha_{\perp A})^\perp: (G(\perp A))^\perp \rightarrow (F(\perp A))^\perp$.

Proposition 5 *Given a monoidal functor F and a monoidal natural transformation α as above, the induced pair F_{\otimes}, F_{\oplus} of functors defines a linear functor, and the induced pair $\alpha_{\otimes}, \alpha_{\oplus}$ of transformations defines a linear transformation.*

Proof. All that must be done is to show that the required commutativity conditions are met. There are essentially six diagrams (five for functors, one for transformations) that we must verify, using only the monoidal forms of the functor boxes. First, we give the reduced forms of several key maps below. As in the Introduction, we shall use the notation $F = F_{\otimes}, \overline{F} = F_{\oplus}$ in these circuits (to save space).

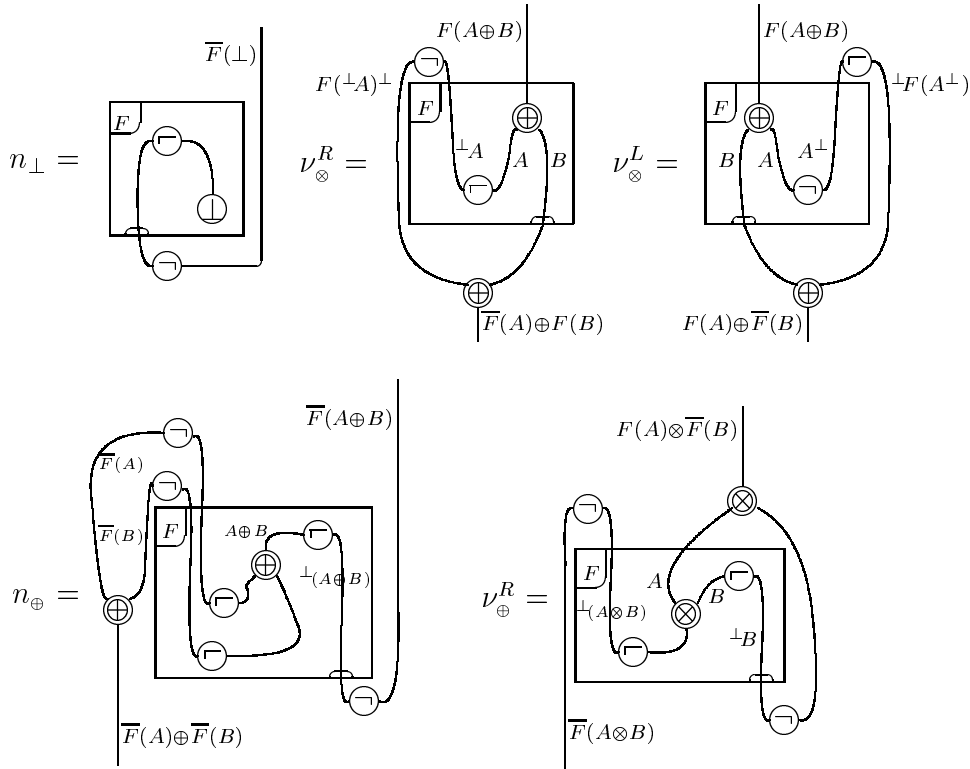

Then to show that $(F_{\otimes}, F_{\oplus})$ is linear, we could either show how to simulate the general F_{\otimes} box and the comonoidal F_{\oplus} box together with their rewrite rules, or we could use the monoidal rewrites for the boxes above and show that the essential five diagrams (and their duals) commute using the monoidal boxes alone. The former we shall leave as an exercise (but note that the comonoidal box is essentially what is illustrated by the circuits above for ν_{\otimes}),

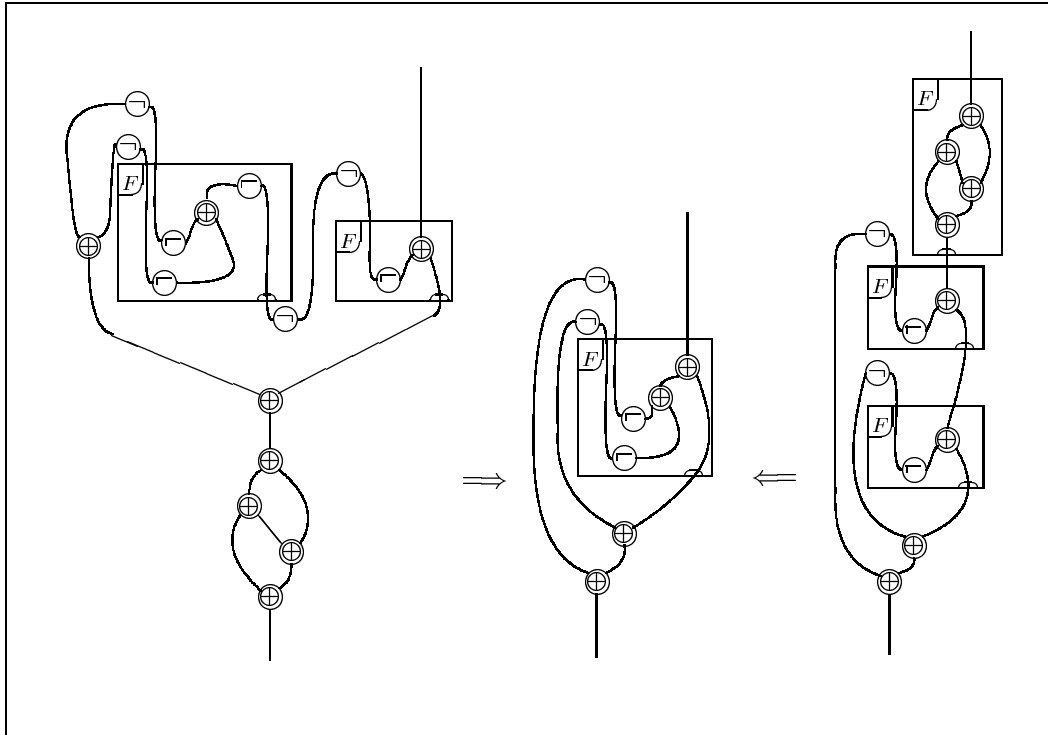

Fig. 10. Validity of equation (5)

instead directly verifying the necessary commutative diagrams. The first diagram (involving the unit \perp) is quite simple, and we leave it to the reader. The next two (involving repeated instances of ν) are fairly similar, so we illustrate only equation (5), which amounts to the equivalences in Figure 10. Equations (7), (8) are handled in a similar manner, as illustrated by the equivalences in Figure 11.

Finally, we must show that if α is a monoidal transformation, the induced $(\alpha_{\otimes}, \alpha_{\oplus})$ is linear. The circuit that simulates the α_{\oplus} node is the α node with negation links before and after to “turn around” the wires. So with this, there is essentially one diagram to verify (the variants being similar), which amounts to the equivalences in Figure 12. And with this we complete the proof that the “de Morgan construction” actually produces linear functors and transformations. \square

Remark 6 In fact, it is also true that a linear functor F between $*$ -autonomous categories is equivalent to the linear functor induced by the monoidal functor F_{\otimes} ; that is, that $F_{\oplus}(A)^{\perp}$ is naturally isomorphic to $F_{\otimes}(A^{\perp})$. We shall leave to the reader the simple exercise of constructing the appropriate maps that characterize linear negation, and showing the necessary coherence for these maps [CS92].

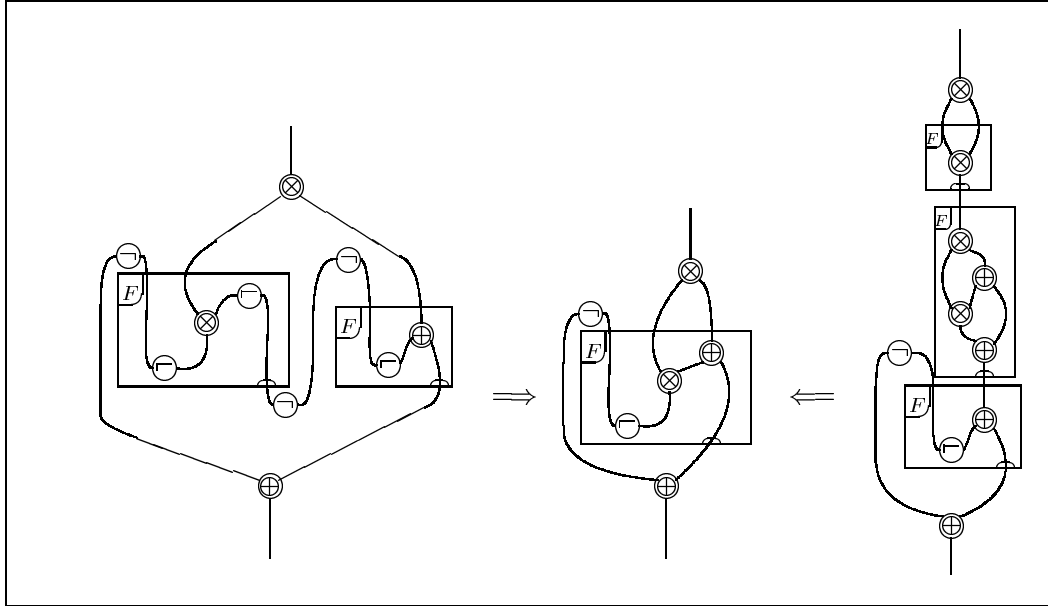

Fig. 11. Validity of equation (7)

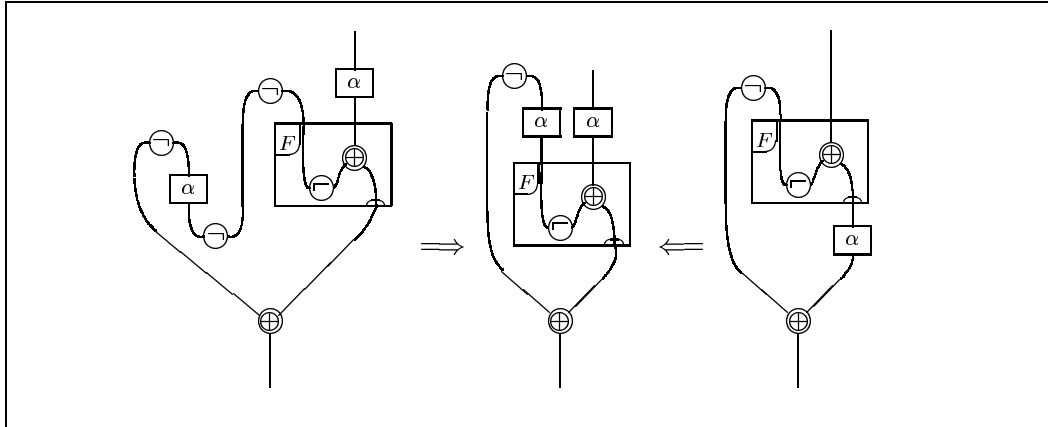

Fig. 12. Validity of equation (11)

3 Linearly distributive and $*$ -autonomous categories

We may summarize the preceding discussion as follows. Let $*\text{-sAUT}$ be the 2-category of (commutative) $*$ -autonomous categories, monoidal functors, and monoidal transformations, and let $*\text{-AUT}$ be (the noncommutative analogue) the category of bilinear categories (as defined in [CS97] for instance—these are just noncommutative $*$ -autonomous categories), monoidal functors F such that ${}^{\perp}(F(A^{\perp})) \cong (F({}^{\perp}A))^{\perp}$, and monoidal transformations.

Proposition 7 *There is an inclusion of 2-categories $U: *\text{-sAUT} \rightarrow \text{SLDC}$, and there is an inclusion of 2-categories $U: *\text{-AUT} \rightarrow \text{LDC}$.*

We want to construct right adjoints (or rather bi-adjoints) to these “forgetful” 2-functors U . This is closely related to the development of a generalization of the notion of “nuclearity” (as defined for compact categories in [R88] and [HR89]), which may be found in Appendix A below. The basic idea is that by constructing the full subcategory of a linearly distributive category consisting of the “complemented objects”, we in fact construct a $*$ -autonomous category, which is the essence of the desired right bi-adjoint. There is a necessary appeal to the axiom of choice in this construction, which may be avoided at the expense of some technical obfuscation; essentially the problem is that even if every object of a category has a complement, that does not explicitly give a $*$ functor (nor even a $*$ function, which suffices by [CS92]) without some use of choice. In the Appendix we shall see that there are several ways of constructing a $*$ -autonomous category from a linearly distributive category; these constructions are related, and we refer the reader to the Appendix for details when necessary.

An object A of a linearly distributive category is said to be complemented if there is an object B and maps $\tau: \top \rightarrow B \oplus A$, $\gamma: A \otimes B \rightarrow \perp$ satisfying the equations

$$\begin{aligned} (u_{\otimes}^R)^{-1}; 1 \oplus \tau; \delta_L^L; \gamma \oplus 1; u_{\oplus}^L &= 1_A \\ (u_{\otimes}^L)^{-1}; \tau \oplus 1; \delta_R^R; 1 \oplus \gamma; u_{\oplus}^R &= 1_B \end{aligned}$$

This definition and the connection with nuclearity are described in detail in the Appendix; see Definition 32 in particular. Then, to a symmetric linearly distributive category \mathbf{X} we assign the full subcategory $C(\mathbf{X})$ of complemented objects. Provided sufficient idempotents split this is just the nucleus of the category \mathbf{X} . The category $C(\mathbf{X})$ is linearly distributive, and since each object has at least one complement, then we may choose a negation for each object, making the category $*$ -autonomous. Note the use of the axiom of choice in this construction. On 1- and 2-cells, C is just defined by restriction. To verify that this is well-defined on 1-cells, we need to know that linear functors preserve complemented objects; this is proved in the Appendix. Then the following is a routine exercise.

Proposition 8 $C: \text{SLDC} \rightarrow * \text{-sAUT}$ is a 2-functor, and moreover is a right bi-adjoint to U .

The noncommutative case requires some more delicacy. One approach is to mimic a construction due to M. Barr of the Chu space of a noncommutative $*$ -autonomous (or bilinear) category [Ba95]. We present a simplified version first in the commutative case, which will avoid the appeal to the axiom of choice we needed above. Instead of taking $C(\mathbf{X})$ to be (essentially) the nucleus of \mathbf{X} , we construct it as follows. The objects of $C(\mathbf{X})$ are pairs (X, X') , where X is a left complement of X' , and so X' is a right complement of X . In this case, the

negation function is simple to define: using the $*$ notation of $*$ -autonomous categories, we have $(X, X')^* = (X', X)$. Morphisms of the category are pairs of arrows of \mathbf{X} , but contravariant in the second variable, so $(f, f'): (X, X') \rightarrow (Y, Y')$ if $f: X \rightarrow Y$ and $f': Y' \rightarrow X'$, satisfying the following commutativity conditions.

$$\begin{array}{ccc}
X \otimes Y' & \xrightarrow{1 \otimes f'} & X \otimes X' \\
f \otimes 1 \downarrow & & \downarrow \gamma \\
Y \otimes Y' & \xrightarrow{\gamma} & \perp
\end{array}
\qquad
\begin{array}{ccc}
\top & \xrightarrow{\tau} & X' \oplus X \\
\tau \downarrow & & \downarrow 1 \oplus f \\
Y' \otimes Y & \xrightarrow{f \oplus 1} & X' \otimes Y
\end{array}$$

It is straightforward to show that this is indeed a $*$ -autonomous category.

In the noncommutative case, we extend this idea by taking doubly infinite sequences of objects $(\dots, X_{-1}, X_0, X_1, \dots)$; more precisely, an object is a function $\mathbb{Z} \rightarrow \text{Obj}(\mathbf{X})$ from the integers to the set of objects of \mathbf{X} , so that the 0-position is readily identifiable in the sequence. Furthermore, we require of such sequences that each pair (X_i, X_{i+1}) is a complementation pair. We suppress the complementation morphisms γ, τ to keep the notation as simple as possible, but they are an essential part of the definition of the objects of the category. An arrow in this category is a doubly infinite sequence of arrows, with the variance alternating, so as to be covariant at even positions, contravariant at odd positions. These arrows must commute with the complementation structure in the evident manner:

$$\begin{array}{ccc}
X_{2n} \otimes Y_{2n+1} & \xrightarrow{1 \otimes f_{2n+1}} & X_{2n} \otimes X_{2n+1} \\
f_{2n} \otimes 1 \downarrow & & \downarrow \gamma \\
Y_{2n} \otimes Y_{2n+1} & \xrightarrow{\gamma} & \perp
\end{array}
\qquad
\begin{array}{ccc}
Y_{2n-1} \otimes X_{2n} & \xrightarrow{f_{2n-1} \otimes 1} & X_{2n-1} \otimes X_{2n} \\
1 \otimes f_{2n} \downarrow & & \downarrow \gamma \\
Y_{2n-1} \otimes Y_{2n} & \xrightarrow{\gamma} & \perp
\end{array}$$

$$\begin{array}{ccc}
\top & \xrightarrow{\tau} & X_{2n+1} \oplus X_{2n} \\
\tau \downarrow & & \downarrow 1 \oplus f_{2n} \\
Y_{2n+1} \otimes Y_{2n} & \xrightarrow{f_{2n+1} \oplus 1} & X_{2n+1} \otimes Y_{2n}
\end{array}
\qquad
\begin{array}{ccc}
\top & \xrightarrow{\tau} & X_{2n} \oplus X_{2n-1} \\
\tau \downarrow & & \downarrow f_{2n} \oplus 1 \\
Y_{2n} \otimes Y_{2n-1} & \xrightarrow{1 \oplus f_{2n-1}} & Y_{2n} \otimes X_{2n-1}
\end{array}$$

In this category, there are two evident negation functions. Again, we shall use the $*$ notation (so as not to conflict with the $()^\perp$ notation). Given a sequence $(\dots, X_{-1}, X_0, X_1, \dots)$, we define the two objects

$$\begin{aligned}
(\cdots, X_{-1}, X_0, X_1, \cdots)^* &= (\cdots, X_0, X_1, X_2, \cdots) \\
*(\cdots, X_{-1}, X_0, X_1, \cdots) &= (\cdots, X_{-2}, X_{-1}, X_0, \cdots)
\end{aligned}$$

(In each case, just shift the sequence one position, right or left, as appropriate.)

Then it becomes straightforward to show that this category is bilinear, or non-commutative $*$ -autonomous; in fact, the proof is essentially given in [Ba95]. Moreover, with this construction of $C(\mathbf{X})$, we can then show the noncommutative version of our main result.

Proposition 9 $C:\text{LDC} \rightarrow *\text{-AUT}$ is a 2-functor, and moreover is a right bi-adjoint to U .

The point of saying this is a bi-adjunction (rather than an adjunction) is that the triangle equalities required of an adjunction hold in this case only up to natural equivalence. In both the symmetric and nonsymmetric cases we can claim a bit more, however: for any \mathbf{A} , the unit $\eta_{\mathbf{A}}$ of this bi-adjunction is a natural equivalence, and so this is a bi-coreflection. For example, in the nonsymmetric case, this unit takes an object A of a $*$ -autonomous category \mathbf{A} to the sequence $(\cdots, {}^\perp A, A, A^\perp, \cdots)$, and it is clear that any other sequence “centered” on A must be isomorphic to this one. The counit of the bi-adjunction evaluates sequences at 0.

4 ! and ? in SLDC

In this section, we shall show that given a linearly distributive category with storage (in the sense of [BCS96]), the “exponential” functors $!$ and $?$ form a linear functor $!$, given by $!_{\otimes} = !$, $!_{\oplus} = ?$. Then storage may be characterized by requiring in SLDC that $!$ be a cotriple whose cofree coalgebras naturally carry cocommutative comonoid structure.

We begin with some preliminaries. First we note that symmetric linearly distributive categories may be presented “internally” in SLDC. We recall that there is a 2-category \mathbf{M} , the “2-theory” of symmetric monoidal categories, whose objects are generated by a single generator, with the property that a symmetric monoidal category may be represented by a product-preserving 2-functor $\mathbf{M} \rightarrow \text{CAT}$ into the 2-category of categories.

Proposition 10 For any \mathbf{X} in SLDC, there is a canonical 2-functor $\hat{\mathbf{X}}:\mathbf{M} \rightarrow \text{SLDC}$ (taking the generator of \mathbf{M} to \mathbf{X}) which preserves products exactly, and moreover, $(-)$ induces a fully faithful 2-functor $\text{SLDC} \rightarrow \text{Lax}(\mathbf{M}, \text{SLDC})$.

More elementarily, this means that in SLDC, each object is canonically a mon-

oidal category; that is, for a symmetric linearly distributive category \mathbf{X} , there is a linear functor $\otimes: \mathbf{X} \times \mathbf{X} \rightarrow \mathbf{X}$ given by $\otimes_{\otimes} = \otimes$ and $\otimes_{\oplus} = \oplus$, and a linear functor $\top: \mathbf{1} \rightarrow \mathbf{X}$ given by $\top_{\otimes} = \top$ and $\top_{\oplus} = \perp$. Further, functors in SLDC are “lax”, in the sense that $m = (m, n)$ is a linear transformation $\langle F, F \rangle; \otimes \rightarrow \otimes; F$ for any linear functor F , where m, n are the natural transformations expressing the monoidal (comonoidal) property of F_{\otimes} (F_{\oplus}), and similarly for the units.

Proof. We can define

$$\begin{aligned} \nu_{\otimes}^R &= (A \oplus B) \otimes (A' \oplus B') \xrightarrow{\delta_R^R} A \oplus (B \otimes (A' \oplus B')) \\ &\xrightarrow{1 \oplus \delta_R^L} A \oplus (A' \oplus (B \otimes B')) \xrightarrow{a_{\oplus}} (A \oplus A') \oplus (B \otimes B') \end{aligned}$$

and similarly for the other linear strengths. Note there is a use of symmetry in the use of the “non-planar” δ_R^L . Some generalization of the present result could be made to the “non-planar weakly distributive categories” of [CS92], but seems unnecessary in the present context.

There are some diagrams to verify. The simplest approach is to use the nets described in [BCST]; in the present cases, these diagrams essentially (after simple reductions) amount to Kelly–MacLane graphs, with some variations in where the crossings occur, and so the necessary equalities hold quite trivially. The reduced normal forms of three of the nets involved may be found in Figure 13. (We have omitted two that are very similar to those for D^5, D^7 ; only a few nodes need different labels, the wiring remaining the same.) Note that all the ν ’s, m_{\otimes} and n_{\oplus} have the same underlying graph, with appropriate labelling of the nodes. The nets D^i refer to the paths of the diagrams from Definition 1, with the subscript indicating which path (top, bottom, left, or right) is intended. We leave dual cases to the reader.

The corresponding linear strengths for the units are quite trivial (essentially being given by unit isomorphisms). To verify that (m, n) is linear involves some standard circuit rewrites (or some diagram chasing) using functor boxes, which we shall leave as an exercise. \square

Next, we turn to the matter of $!$ and $?$ as linear functors. In [BCS96] we defined a notion of relative tensorial strength, and required that $?$ be relatively strong, $!$ relatively costrong. Here, we note that in the presence of the triple and cotriple structure there is an alternate presentation of the notion of relative tensorial strength in terms of the linear strengths that we have introduced in the definition of linear functors.

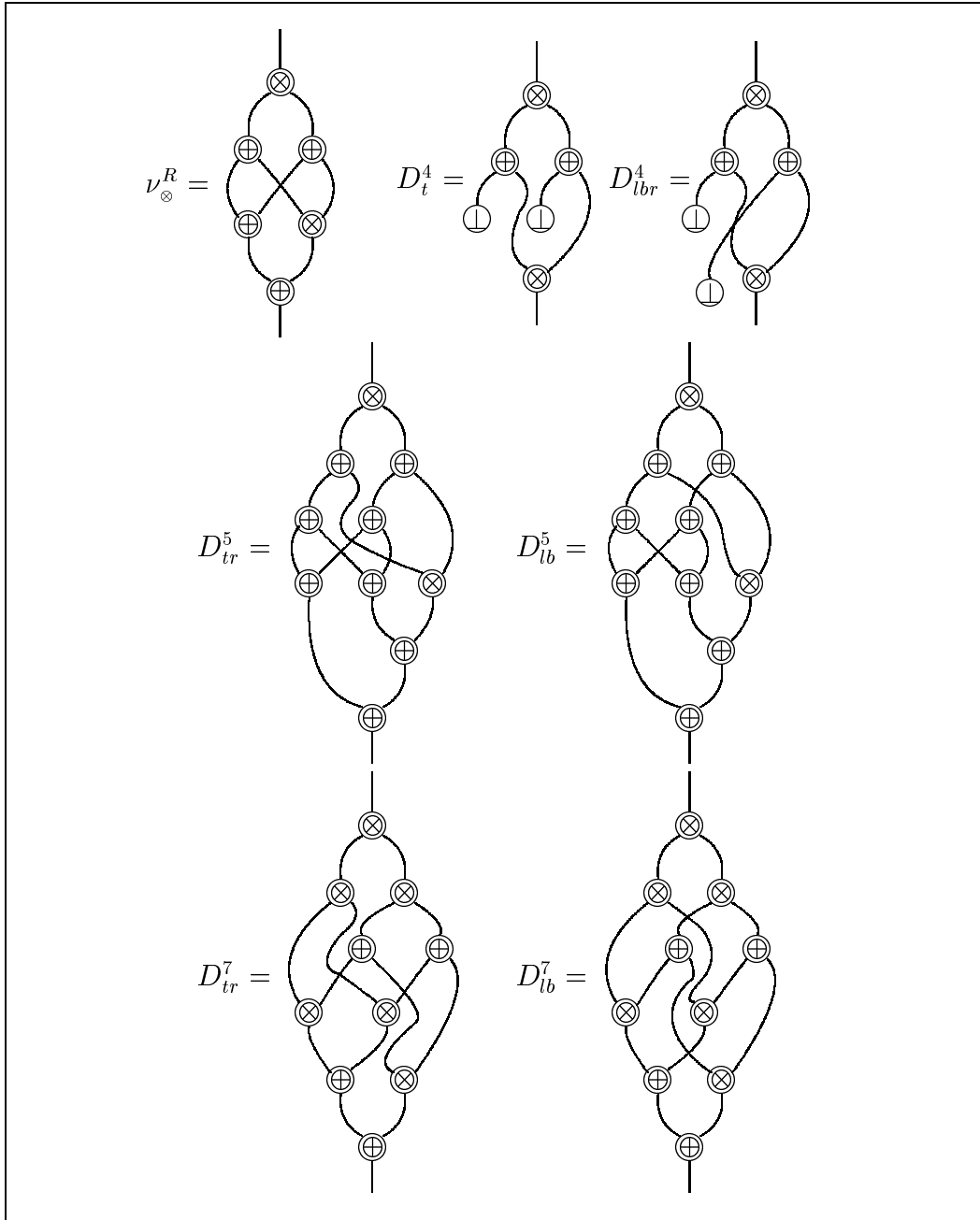

Fig. 13. Nets needed to show coherence for \otimes

Lemma 11 *Suppose given a monoidal category \mathbf{X} (whose tensor is denoted \oplus) and two endofunctors $!$ and $?$ on \mathbf{X} , so that $?$ is a triple. Then there is a bijective correspondence between natural transformations $\phi: !(A \oplus ? B) \rightarrow !A \oplus ? B$ and natural transformations $\nu: !(A \oplus B) \rightarrow !A \oplus ? B$. Similarly, suppose given a monoidal category \mathbf{X} (whose tensor is denoted \otimes) and two endofunctors $!$ and $?$ on \mathbf{X} , so that $!$ is a cotriple. Then there is a bijection between $\theta: ? A \otimes ! B \rightarrow ?(A \otimes ! B)$ and $\nu': ? A \otimes ! B \rightarrow ?(A \otimes B)$.*

Remark Note that this lemma really does not depend on any special prop-

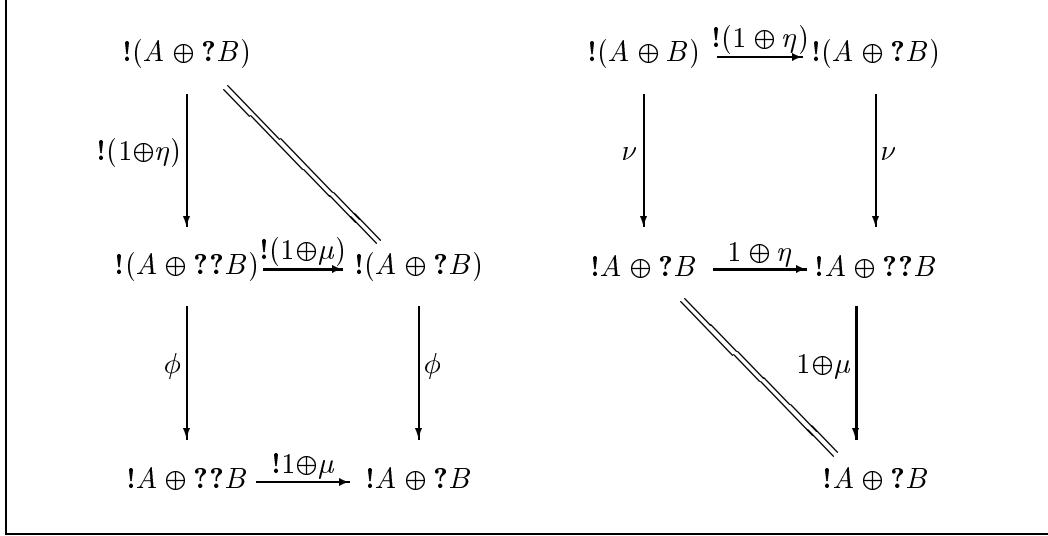

Fig. 14. Diagrams verifying the bijection $\phi \leftrightarrow \nu$

erties of the monoidal category, and could indeed be stated in terms of any bifunctor instead of the tensor product or par.

Proof. We prove the first statement; the second is a simple dual. Given a natural transformation $\phi: !(A \oplus ?B) \rightarrow !A \oplus ?B$, define a natural transformation $\nu_\phi = !(A \oplus B) \xrightarrow{!(1 \oplus \eta)} !(A \oplus ?B) \xrightarrow{\phi} !A \oplus ?B$, and conversely, given $\nu: !(A \oplus B) \rightarrow !A \oplus ?B$ define $\phi_\nu = !(A \oplus ?B) \xrightarrow{\nu} !A \oplus ?B \xrightarrow{1 \oplus \mu} !A \oplus ?B$. Here, η is the unit of the triple $?$, and μ is its “multiplication”. These constructions are inverse, as may be seen from the diagrams of Figure 14. \square

Next, we note that this makes $\mathbb{!}$ a linear functor. (We shall use the definitions and notation of [BCS96] in this section.)

Lemma 12 *If \mathbf{X} is a linearly distributive category with storage, then $\mathbb{!}$ (as defined above) is a linear functor. Moreover, (ϵ, η) , (δ, μ) , (e, i) , and (d, c) are linear transformations.*

Proof. Again, this is most easily shown using the nets [BCS96]. For the most part the net rewrites are straightforward; we illustrate only a representative sample, and just give the common reductions of nets corresponding to equal maps. (The reader ought to be familiar with the net rewrites of [BCS96].) To begin with, we note that the condition that all the relevant functors and transformations are monoidal is part of the definition of a linearly distributive

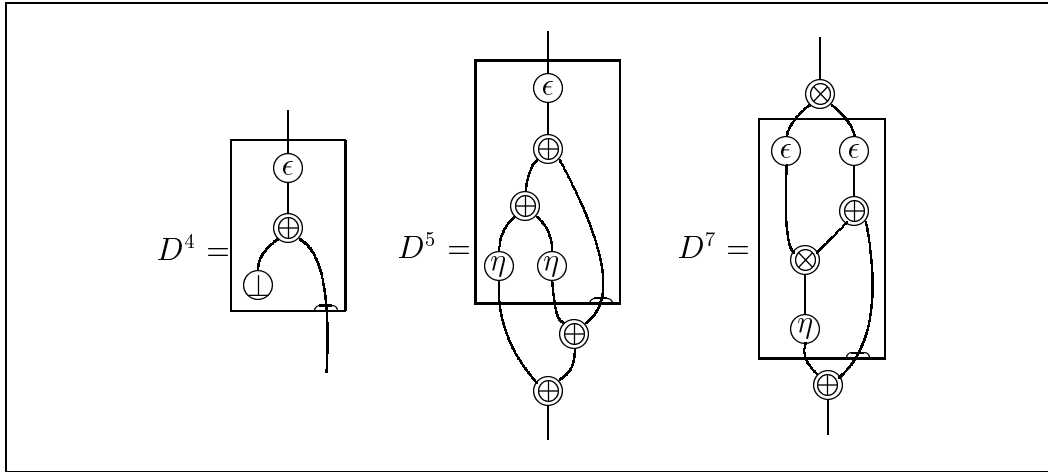

Fig. 15. Nets needed to show $\mathbb{!}$ is linear

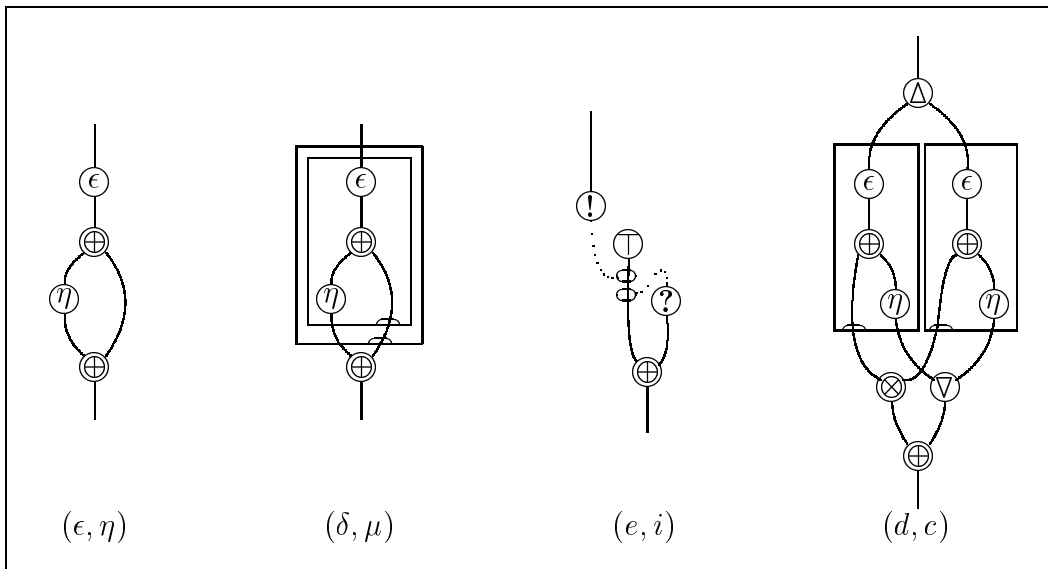

Fig. 16. Nets needed to show some transformations are linear

category with storage. So we just have to define the linear strengths, which is essentially the content of Lemma 11, and show the corresponding coherence conditions are satisfied. To show $\mathbb{!}$ is linear, there are essentially five diagrams (and their duals) to verify; the common reductions for three of these are shown in Figure 15; again D^i refers to the i^{th} diagram from Definition 1. To conserve space, we have omitted D^6 which is similar to D^5 , and D^8 which is similar to D^7 : in each case, the main alteration involves switching the wire carrying the η node with the wire passing through the principal port. To show that there are linear transformations given by the pairs (ϵ, η) , (δ, μ) , (e, i) , and (d, c) , there are essentially four diagrams to verify (and their duals), one for each transformation. These are illustrated in Figure 16, where the common reduced form is shown in each case. \square

Proposition 13 *The following are equivalent:*

- (i) \mathbf{X} is a symmetric linearly distributive category with storage [BCS96].
- (ii) In SLDC \mathbf{X} has a cotriple $!$ carrying a compatible cocommutative comonoid structure.

Remark 14

- (i) To require of a cotriple $!$ that it carries a compatible cocommutative comonoid structure means the following:
 - (a) for each object A , $!A$ is naturally a cocommutative comonoid,
 - (b) the comonoid structure maps are coalgebra maps, and
 - (c) the coalgebra structure map $\delta: !A \rightarrow !!A$ is a comonoid map.
This means that the diagrams given below must commute.

$$\begin{array}{ccc}
!A & \xrightarrow{e} & \top \\
\downarrow \delta & & \downarrow m \\
!!A & \xrightarrow{!e} & !\top
\end{array}
\qquad
\begin{array}{ccc}
!A & \xrightarrow{d} & !A \otimes !A \\
\downarrow \delta & & \downarrow \delta \otimes \delta \\
!!A & \xrightarrow{!d} & !!A \otimes !!A \\
& & \downarrow m \\
& & !(!A \otimes !A)
\end{array}$$

$$\begin{array}{ccc}
!A & \xrightarrow{d} & !A \otimes !A \\
\downarrow \delta & & \downarrow \delta \otimes \delta \\
!!A & \xrightarrow{d} & !!A \otimes !!A
\end{array}
\qquad
\begin{array}{ccc}
!A & \xrightarrow{e} & \top \\
& \searrow \delta & \nearrow e \\
& & !!A
\end{array}$$

- (ii) These diagrams are part of the definition in [BCS96, pp. 330–332]. In clause (ii) of the proposition above they are interpreted in the 2–category SLDC. Thus we automatically obtain the dual version of the diagrams and the coherence with respect to linear strength.
- (iii) Having a monoidal cotriple $!$ carry a compatible cocommutative comonoid structure amounts to having the tensor lift to a cartesian product in the Eilenberg–Moore category of coalgebras. Hence, considering the two components of $!$, and using the evident duality, we can remark that the Eilenberg–Moore category for $!$ will have products, and the Eilenberg–Moore category (of algebras) for $?$ will have coproducts.

Proof (of Proposition 13) All the basic structure (in both directions) is assured by the previous lemmas; all that remains to do is to show that the appropriate diagrams commute. The direction (i) \Rightarrow (ii) is essentially done in Lemma 12. For the converse, we have some further work, to show that the

strength of θ and the costrength of ϕ , likewise the strength of i, c and the costrength of e, d , follow from the linearity of the various functors and transformations. However, it is easy to check all the diagrams given in [BCS96, pp. 328, 329, 331] that involve strength or costrength, to verify that they commute when the strength and costrength are induced from the linearity of $!$ and the corresponding transformations. There are eight diagrams to check (plus their duals); we illustrate these in Figure 17 with just four, which show how the various elements come into play: the various functors and transformations are (monoidal (mon) and) linear (lin), the functor $?$ is a triple (trip), the algebra maps must be monoid maps (alg), and so on.

For the rest of the conditions, [BCS96, pp. 325, 326, 330, 331(top), 332] not involving strength or costrength, those on pp. 325, 326, 330(top) just express that various transformations are monoidal, which is included in the assumption of linearity, and the rest are those above which define the “compatibility” assumption. This completes the proof. \square

We can state the content of the previous Proposition in the following fashion, which internalizes the $!$ and $?$ structure. We note first that there is a 2–category, \mathbf{Mell} , which is the 2–theory of symmetric monoidal categories with $!$ (or MELL categories), and an inclusion $\mathbf{M} \rightarrow \mathbf{Mell}$, corresponding to the “forgetful” interpretation which to a MELL category assigns the underlying monoidal category. Furthermore, we shall define a 2–category $\mathbf{SLDC}_!$ consisting of symmetric linearly distributive categories with storage (*i.e.* those \mathbf{X} (together with the specified $!$) that satisfy the conditions of the previous Proposition), and linear functors and transformations that preserve the $!$ structure.

Corollary 15 *For any object (0-cell) $\langle \mathbf{X}, ! \rangle$ in $\mathbf{SLDC}_!$, there is a canonical 2–functor $\hat{\mathbf{X}}: \mathbf{Mell} \rightarrow \mathbf{SLDC}$ (taking the generator of \mathbf{Mell} to \mathbf{X} and the $!$ of \mathbf{Mell} to $!$) which preserves products exactly. Moreover, $(\hat{-})$ induces a fully faithful 2–functor $\mathbf{SLDC}_! \rightarrow \mathbf{Lax}(\mathbf{Mell}, \mathbf{SLDC})$, which is the pullback in \mathbf{CAT} of the 2–functor from Proposition 10 along the forgetful interpretation.*

$$\begin{array}{ccc}
 \mathbf{SLDC} & \longrightarrow & \mathbf{Lax}(\mathbf{M}, \mathbf{SLDC}) \\
 \uparrow & & \uparrow \\
 \mathbf{SLDC}_! & \longrightarrow & \mathbf{Lax}(\mathbf{Mell}, \mathbf{SLDC})
 \end{array}$$

Finally, a special case that is worth mentioning:

Corollary 16 *A (symmetric) $*$ -autonomous category \mathbf{X} with a cotriple $!$ carrying a compatible cocommutative comonoid structure is a linearly distributive*

category with storage.

This result is almost automatic, in view of the inclusion of $*$ -autonomous categories into LDC. The only point here is that in $*$ -autonomous categories the duality guarantees the de Morgan dual structure, so one only need refer to $!$, and $?$ comes along for free. In the next section we shall see a similar story for cartesian products.

5 Adding the additives

In this section we shall look at the effect of requiring of a linearly distributive category \mathbf{X} that it have a linear functor $\times: \mathbf{X} \times \mathbf{X} \rightarrow \mathbf{X}$, given by $\times_{\otimes} = \times$ and $\times_{\oplus} = +$, which acts as a cartesian product in the 2-category SLDC, so that linear transformations corresponding to diagonal and projections are present. We shall see that this amounts to having distributive cartesian product and coproduct, distributive not with respect to each other, but with respect to tensor and par, as one would expect, for example, in a FILL³ and coFILL category, where the adjoints to tensor and par guarantee such distributivity because of exactness.

We begin with the simple matter of “linear” terminal objects in linearly distributive categories. This will give some idea of what to expect when we consider linear products.

Definition 17 \mathbf{X} has a linearly presented, or more simply, a “linear”, terminal object if there is a linear constant functor $\mathbb{1}: \mathbf{1} \rightarrow \mathbf{X}$, $\mathbb{1} = (1, 0)$ and a linear transformation $!: \text{Id}_{\mathbf{X}} \rightarrow \mathbb{1}: \mathbf{X} \rightarrow \mathbf{X}$, $! = (!, j)$. These must satisfy the usual equation for a terminal object: $!\mathbb{1} = id_{\mathbb{1}}: \mathbb{1} \rightarrow \mathbb{1}: \mathbf{1} \rightarrow \mathbf{X}$.

Here $\mathbb{1}'$ is the canonical composite $\mathbf{X} \rightarrow \mathbf{1} \xrightarrow{\mathbb{1}} \mathbf{X}$. Note that this is equivalent to the usual equation for a terminal object (in the monoidal coordinate) and an initial object (in the comonoidal coordinate).

Notational overload: please note that $!$ here represents the unique map from an arbitrary object to the terminal object, and has nothing to do with the “storage” functor of Section 4. Since the former usage was as a functor and the current usage is as a transformation, there ought to be no confusion.

Before proceeding, we justify the notation: the proof of the following lemma

³ See the Appendix to recall the meaning of these terms.

is trivial.

Lemma 18 *If \mathbf{X} has a linear terminal object, then it has a terminal object and an initial object in the usual sense, given by $\mathbb{1}_\otimes, \mathbb{1}_\oplus$ respectively. For an object A , the unique maps $A \xrightarrow{!_A} 1$ and $0 \xrightarrow{i_A} A$ are given by $\mathbb{!}_\otimes(A), \mathbb{!}_\oplus(A)$ respectively.*

More importantly, linear terminal objects are distributive, and indeed, this gives a simpler equivalent presentation of this notion.

Proposition 19 *If \mathbf{X} is a linearly distributive category, the following are equivalent.*

- (i) \mathbf{X} has a linear terminal object $\mathbb{1}$.
- (ii) \mathbf{X} has a terminal object 1 , an initial object 0 , and these are “distributive”, in the sense that 1 is preserved by PAR and 0 is preserved by TENSOR:

$$0 \xrightarrow{\sim} A \otimes 0 \quad A \oplus 1 \xrightarrow{\sim} 1$$

are isomorphisms for any object A .

Proof. (i) \Rightarrow (ii) We consider the case with the terminal object (the other case is dual). First, note that the constant linear functor $\mathbb{1}$ comes equipped with a map $\nu = \nu_\otimes^R: 1 \rightarrow 0 \oplus 1$, which induces a map $1 \rightarrow A \oplus 1$ for any object A , namely $1 \xrightarrow{\nu} 0 \oplus 1 \xrightarrow{i^{\oplus 1}} A \oplus 1$. So the only thing we need to verify is that the composite $A \oplus 1 \rightarrow 1 \rightarrow A \oplus 1$ is the identity; this is then an instance of the linearity of the transformation $\mathbb{!}$. (Explicitly, this becomes an instance of equation 11 with $B = 1$.)

(ii) \Rightarrow (i) Conversely, it is trivial that $\mathbb{1}_\otimes$ is monoidal and $\mathbb{1}_\oplus$ is comonoidal. The linear strengths ν are given using the inverses to the terminal morphisms (which are assumed to be isomorphisms). And the linearity of the functor $\mathbb{1}$ and of the transformation $\mathbb{!}$ is again trivial, using the fact that all the objects of the form $X \oplus 1$ are terminal, and all objects of the form $X \otimes 0$ are initial. \square

Remark 20 Note that there is actually some structure involved in demanding of a “point” $\mathbb{1} \rightarrow \mathbf{X}$ of \mathbf{X} that it be linear. This raises the question “what are the linear points of a linearly distributive category?” Clearly, such a linear point is a pair of objects of \mathbf{X} , and moreover, this pair must lie in the nucleus of \mathbf{X} . Also, since the (single) object of $\mathbb{1}$ is both a commutative monoid and a commutative comonoid, the \otimes component of the pair must be a commutative monoid, and the other component must be a cocommutative comonoid. We may call such pairs “nuclear monoids”, and then it is easy to see that the

collection of such nuclear monoids is just the collection of linear points. It is easy to see that the category of linear points has coproducts.

Now we turn to the matter of “linear products”.

Definition 21 *A linearly distributive category \mathbf{X} has linearly presented, or simply “linear”, binary products if there is a linear functor $\varkappa: \mathbf{X} \times \mathbf{X} \rightarrow \mathbf{X}$, $\varkappa_{\otimes} = \times$ and $\varkappa_{\oplus} = +$, and linear transformations $\Delta: \text{Id}_{\mathbf{X}} \rightarrow \varkappa \circ \Delta_{\mathbf{X}}: \mathbf{X} \rightarrow \mathbf{X}$, $\Delta = (\Delta, \nabla)$, and $\varkappa_i: \varkappa \rightarrow \pi_i^{\mathbf{X}^2}: \mathbf{X} \times \mathbf{X} \rightarrow \mathbf{X}$, $\varkappa_i = (p_i, b_i)$, ($i = 0, 1$). Furthermore, these must satisfy the standard equations for cartesian products (as in [LS86] for example).*

$$\begin{aligned} \Delta; \varkappa_0 \varkappa_1 &= id_{\varkappa}: \varkappa \rightarrow \varkappa: \mathbf{X} \times \mathbf{X} \rightarrow \mathbf{X} \\ \Delta; \varkappa_i &= id: id \rightarrow id: \mathbf{X} \rightarrow \mathbf{X} \quad (i = 0, 1) \end{aligned}$$

Note that given our definition of composition of linear transformations, these are equivalent to the usual equations for products (in the monoidal coordinate) and coproducts (in the comonoidal coordinate).

As with terminal and initial objects, the following is evident.

Lemma 22 *If \mathbf{X} has linear products, then it has cartesian products and coproducts in the usual sense, given by $\varkappa_{\otimes}, \varkappa_{\oplus}$ respectively. For the products, the diagonal and the projections are given by $\Delta_{\otimes}, \varkappa_{i\otimes}$ respectively, and for the coproducts the codiagonal and the injections are given by $\Delta_{\oplus}, \varkappa_{i\oplus}$ respectively.*

More importantly, linear products are distributive in the appropriate sense.

Lemma 23 *If \mathbf{X} has linear products, then the induced cartesian product is preserved by par, in that there is a natural transformation*

$$(A \oplus B) \times (A \oplus C) \xrightarrow{\nu_{\otimes}^R} (A + A) \oplus (B \times C) \xrightarrow{\nabla_{\oplus 1}} A \oplus (B \times C)$$

inverse to the canonical transformation

$$A \oplus (B \times C) \xrightarrow{\langle 1_{\oplus p_0}, 1_{\oplus p_1} \rangle} (A \oplus B) \times (A \oplus C).$$

Dually, the induced cartesian coproduct is preserved by tensor; that is, there is a natural transformation

$$A \otimes (B + C) \xrightarrow{\Delta_{\otimes 1}} (A \times A) \otimes (B + C) \xrightarrow{\nu_{\oplus}^R} (A \otimes B) + (A \otimes C)$$

which is inverse to the canonical transformation

$$(A \otimes B) + (A \otimes C) \xrightarrow{\langle 1_{\otimes b_0} | 1_{\otimes b_1} \rangle} A \otimes (B + C).$$

Proof. The proof of this lemma is a fairly routine exercise in diagram chasing. For example, to show that we have an isomorphism $(A \otimes B) + (A \otimes C) \rightarrow A \otimes (B + C)$ we must show the two composites are the identities. For the identity on $(A \otimes B) + (A \otimes C)$, it suffices to show the two components are b_0, b_1 respectively. The diagram for b_0 is given below, the one for b_1 is similar.

$$\begin{array}{ccccc}
A \otimes (B + C) & \xrightarrow{\Delta \otimes 1} & (A \times A) \otimes (B + C) & \xrightarrow{\nu_{\oplus}^R} & (A \otimes B) + (A \otimes C) \\
\uparrow 1 \otimes b_0 & & \uparrow 1 \otimes b_0 & \text{(lin)} & \uparrow b_0 \\
A \otimes B & \xrightarrow{\Delta \otimes 1} & (A \times A) \otimes B & \xrightarrow{p_0 \otimes 1} & A \otimes B \\
\downarrow & & \downarrow & & \downarrow \\
& \xrightarrow{\quad \quad \quad} & & & \\
& \text{=} & & &
\end{array}$$

For the composite giving the identity on $A \otimes (B + C)$, the following diagram does the trick. (Note the left-hand path is the identity on $A \otimes (B + C)$ since $+$ is a coproduct.)

$$\begin{array}{ccccc}
A \otimes (B + C) & \xrightarrow{\Delta \otimes 1} & (A \times A) \otimes (B + C) & \xrightarrow{\nu_{\oplus}^R} & (A \otimes B) + (A \otimes C) \\
\downarrow 1 \otimes (b_0 + b_1) & \text{(nat)} & \downarrow 1 \otimes (b_0 + b_1) & \text{(nat)} & \downarrow (1 \otimes b_0) + (1 \otimes b_1) \\
A \otimes ((B + C) + (B + C)) & \xrightarrow{\Delta \otimes 1} & (A \times A) \otimes ((B + C) + (B + C)) & \xrightarrow{\nu_{\oplus}^R} & (A \otimes (B + C)) + (A \otimes (B + C)) \\
\searrow 1 \otimes \nabla & & \text{(lin)} & & \swarrow \nabla \\
& & A \otimes (B + C) & &
\end{array}$$

□

Moreover, such distributivity is equivalent to the full linear structure.

Proposition 24 *If \mathbf{X} is a linearly distributive category, the following are equivalent.*

- (i) \mathbf{X} has linear binary products.
- (ii) \mathbf{X} has distributive binary products and coproducts, in the sense that \times is preserved by PAR and $+$ is preserved by TENSOR. In other words, the canonical maps

$$\begin{aligned}
A \oplus (B \times C) &\xrightarrow{\langle 1 \oplus p_0, 1 \oplus p_1 \rangle} (A \oplus B) \times (A \oplus C) \\
(A \otimes B) + (A \otimes C) &\xrightarrow{\langle 1 \otimes b_0 | 1 \otimes b_1 \rangle} A \otimes (B + C)
\end{aligned}$$

are natural isomorphisms for any objects A, B, C .

Proof. $(i) \Rightarrow (ii)$ has been proved in Lemma 23, so we only need to show $(ii) \Rightarrow (i)$. Given suitably “distributive” products and coproducts, we define the linear functor \times and the corresponding linear transformations in the evident way. The linear strengths may be defined in terms of distributivity; for example, the transformation ν_{\otimes}^R is

$$\begin{aligned}
(A \oplus B) \times (A' \oplus B') &\xrightarrow{(b_0 \oplus 1) \times (b_1 \oplus 1)} ((A + A') \oplus B) \times ((A + A') \oplus B') \\
&\xrightarrow{\partial} (A + A') \oplus (B \times B')
\end{aligned}$$

where ∂ is the isomorphism given by distributivity.

We must then show that this does indeed make \times and the appropriate transformations linear, and moreover, that these two ways of defining cartesian products and coproducts are equivalent. This means checking a number of coherence diagrams, which is just a routine diagram chase. Before sketching some of the details, however, we can verify that at the level of morphisms things do agree: if we have linear products and use the induced distributivity to define “new” linear distributions ν , then indeed, these are just the original ν ’s we started with. For instance, in the case of ν_{\oplus}^R , this amounts to the commutativity of the following diagram.

$$\begin{array}{ccccc}
(A \times A') \otimes (B + B') & \xrightarrow{\cong} & (A \times A') \otimes (B + B') & \xrightarrow{\nu_{\oplus}^R} & (A \otimes B) + (A' \otimes B') \\
\searrow \Delta \otimes 1 & & \nearrow (p_0 \times p_1) \otimes 1 & & \uparrow (p_0 \otimes 1) + (p_1 \otimes 1) \\
((A \times A') \times (A \times A')) \otimes (B + B') & \xrightarrow{\nu_{\oplus}^R} & ((A \times A') \otimes B) + ((A \times A') \otimes B') & &
\end{array}$$

In the other direction, given a distributivity $\partial_{\times}: (A \oplus B) \times (A \oplus C) \rightarrow A \oplus (B \times C)$, then the induced distributivity (*via* the induced ν) is the outer path in the diagram below. The diagram commutes (so the induced distributivity equals the original one) because the inner square commutes by naturality, and

the triangle is the identity on $(A \oplus B) \times (A \oplus C)$ by the coproduct equalities.

$$\begin{array}{ccccc}
(A \oplus B) \times (A \oplus C) & \xrightarrow{\cong} & (A \oplus B) \times (A \oplus C) & \xrightarrow{\partial_\times} & A \oplus (B \times C) \\
\searrow (b_0 \oplus 1) \times (b_1 \oplus 1) & & \nearrow (\nabla \oplus 1) \times (\nabla \oplus 1) & & \uparrow \nabla \oplus 1 \\
((A+A) \oplus B) \times ((A+A) \oplus C) & \xrightarrow{\partial_\times} & & & (A+A) \oplus (B \times C)
\end{array}$$

The verification of the coherence diagrams for linearity is a straightforward diagram chase; the key trick is to break the diagrams into smaller ones by reducing to components. We shall illustrate this with one example, equation 8, which is the following diagram.

$$\begin{array}{ccc}
& \xrightarrow{1 \otimes ((1 \oplus b_0) \times (1 \oplus b_1))} & \\
(A \times A') \otimes ((B \oplus C) \times (B' \oplus C')) & & (A \times A') \otimes ((B \oplus (C+C')) \times (B' \oplus (C+C'))) \\
\downarrow \langle p_0 \otimes p_0, p_1 \otimes p_1 \rangle & & \downarrow 1 \otimes \partial'_\times \\
(A \otimes (B \oplus C)) \times (A' \otimes (B' \oplus C')) & & (A \times A') \otimes ((B \times B') \oplus (C+C')) \\
\downarrow \delta_L^L \times \delta_L^L & & \downarrow \delta_L^L \\
((A \otimes B) \oplus C) \times ((A' \otimes B') \oplus C') & & ((A \times A') \otimes (B \times B')) \oplus (C+C') \\
\downarrow (1 \oplus b_0) \times (1 \oplus b_1) & & \downarrow \langle p_0 \otimes p_0, p_1 \otimes p_1 \rangle \oplus 1 \\
((A \otimes B) \oplus (C+C')) \times ((A \otimes B) \oplus (C+C')) & & ((A \otimes B) \times (A' \otimes B')) \oplus (C+C') \\
& \xrightarrow{\partial'_\times} &
\end{array}$$

The bottom arrow ∂'_\times is inverse to $\langle p_0 \oplus 1, p_1 \oplus 1 \rangle$, and so can be reversed. Hence we can establish the diagram's commutativity by looking instead at the commutativity of the two diagrams corresponding to the two projections into $(A \otimes B) \oplus (C+C')$ and into $(A \otimes B) \oplus (C+C')$. We shall illustrate the first

projection.

$$\begin{array}{ccc}
& \xrightarrow{1 \otimes ((1 \oplus b_0) \times (1 \oplus b_1))} & \\
(A \times A') \otimes ((B \oplus C) \times (B' \oplus C')) & & (A \times A') \otimes ((B \oplus (C+C')) \times (B' \oplus (C+C'))) \\
\downarrow p_0 \otimes p_0 & & \downarrow p_0 \otimes p_0 \\
A \otimes (B \oplus C) & \xrightarrow{1 \otimes (1+b_0)} & A \otimes (B \oplus (C+C')) \\
\downarrow \delta_L^L & & \downarrow \delta_L^L \\
(A \otimes B) \oplus C & & ((A \times A') \otimes (B \times B')) \oplus (C+C') \\
\downarrow 1 \oplus b_0 & \searrow \delta_L^L & \downarrow (p_0 \otimes p_0, p_1 \otimes p_1) \oplus 1 \\
(A \otimes B) \oplus (C+C') & \xrightarrow{(p_0 \otimes p_0) \oplus 1} & ((A \otimes B) \times (A' \otimes B')) \oplus (C+C') \\
& \xrightarrow{p_0 \oplus 1} &
\end{array}$$

□

We can state the content of the previous Proposition in terms of the 2–theory \mathbf{Mad} of symmetric monoidal “cartesian” (finite product) categories. As before there is an inclusion $\mathbf{M} \rightarrow \mathbf{Mad}$ which allows the evident 2–category \mathbf{SLDC}_\times of cartesian linearly distributive categories to be formed by a pullback.

Corollary 25 *For any \mathbf{X} in \mathbf{SLDC}_\times , there is a canonical 2–functor $\hat{\mathbf{X}}: \mathbf{Mad} \rightarrow \mathbf{SLDC}$ (taking the generator of \mathbf{Mad} to \mathbf{X}) which preserves products exactly. Moreover, $(\hat{-})$ induces a fully faithful 2–functor $\mathbf{SLDC}_\times \rightarrow \mathbf{Lax}(\mathbf{Mad}, \mathbf{SLDC})$, which is the pullback in \mathbf{CAT} of the 2–functor from Proposition 10 along the forgetful interpretation.*

$$\begin{array}{ccc}
\mathbf{SLDC} & \longrightarrow & \mathbf{Lax}(\mathbf{M}, \mathbf{SLDC}) \\
\uparrow & & \uparrow \\
\mathbf{SLDC}_\times & \longrightarrow & \mathbf{Lax}(\mathbf{Mad}, \mathbf{SLDC})
\end{array}$$

Note in this, as well as in Corollary 15, we are in effect showing how this framework forces the correct definitions once one has the “naive” theory in

the monoidal context.

Again, the special case of $*$ -autonomous categories is worth mention:

Corollary 26 *A $*$ -autonomous category \mathbf{X} with finite products is a linearly distributive category with linear finite products.*

Proof. This is automatic, in view of the inclusion of $*$ -autonomous categories into LDC; again, the duality guarantees the de Morgan dual structure. \square

It is worth comparing the semantics for linear logic developed from the current perspective of linear structure with the semantics defined in [Se89], as clarified by Bierman [B95]. If one has a $*$ -autonomous category with products and a cotriple $!$ carrying a compatible cocommutative comonoid structure, then it is straightforward to show that there are isomorphisms $!A \otimes !B \xrightarrow{\sim} !(A \times B)$ and $\top \xrightarrow{\sim} !1$. In fact, one does not even need linearity for the products, and so this result is true in the 2-theory \mathbf{Mellad} of monoidal categories with storage and products. This was first noticed by Bierman [B95]. So these “Seely isomorphisms” exist in any linearly distributive category with linear storage and products. Once one knows that, it is routine to verify that the semantics of the storage rule given in [Se89,B95] (in terms of the “Seely isomorphisms”) coincides with that given in [BCS96]; since the rest of the semantics in the two treatments is just the same, this reassures us that in this context, the semantics of [Se89,B95] and the semantics in terms of linearly distributive categories with storage and distributive products coincide.

Remark 27 We end with the following observation concerning the existence of linearly distributive categories with linear products. Hu and Joyal [HJ97, and other papers therein cited] point out that if one forms the limit–colimit completion of a linearly distributive category, the result will also be linearly distributive. But since the linearity of the product follows from distributivity, and since distributivity clearly follows from their notion of *softness*, we may conclude that this bicompletion process will give linear products.

Acknowledgement

This paper had its origins in discussions we had with Rick Blute on nuclearity, and is heavily influenced by those discussions. We record here our indebtedness to him for his helpful conversations and advice. Over the years, our work on this project has benefited from Mike Barr’s wisdom and advice in so many ways (even the improved terminology *linearly distributive* was a suggestion of

his). This paper was first presented at a conference held in Montreal in May 1997, in honour of his 60th birthday, and is dedicated to him in celebration of this occasion.

References

- [Ba95] M. Barr “Non-symmetric $*$ -autonomous categories”, *Theoretical Computer Science* **139** (1995), 115–130.
- [B95] G.M. Bierman “What is a categorical model of intuitionistic linear logic?”, in M. Dezani (ed.), *Proceedings of Conference on Typed lambda calculus and Applications*, Springer-Verlag (1995). (Also: Technical Report 333, University of Cambridge, 1994.)
- [BCS96] R.F. Blute, J.R.B. Cockett, and R.A.G. Seely “! and ?: Storage as tensorial strength”, *Mathematical Structures in Computer Science* **6** (1996), 313–351.
- [BCST] R.F. Blute, J.R.B. Cockett, R.A.G. Seely, and T.H. Trimble “Natural deduction and coherence for weakly distributive categories”, *Journal of Pure and Applied Algebra* **113** (1996) 229–296.
- [CS92] J.R.B. Cockett and R.A.G. Seely “Weakly distributive categories”, in M.P. Fourman, P.T. Johnstone, A.M. Pitts, eds., *Applications of Categories to Computer Science*, London Mathematical Society Lecture Note Series **177** (1992) 45–65.
- [CS92j] J.R.B. Cockett and R.A.G. Seely “Weakly distributive categories”, *Journal of Pure and Applied Algebra* **114** (1997) 133–173. (Updated version available on <http://www.math.mcgill.ca/~rags>.)
- [CS97] J.R.B. Cockett and R.A.G. Seely “Proof theory for full intuitionistic linear logic, bilinear logic, and MIX categories”, *Theory and Applications of Categories* **3** (1997) 85–131.
- [G95] J.-Y. Girard “Light linear logic”, preprint, 1995, (revised 1997).
URL: <ftp://lmd.univ-mrs.fr/pub/girard/LLL.ps.Z>
- [HR89] D.A. Higgs and K.A. Rowe “Nuclearity in the category of complete semilattices”, *Journal of Pure and Applied Algebra* **57** (1989) 67–78.
- [HJ97] H. Hu and A. Joyal “Coherence completions of categories”, in S. Brookes and M. Mislove (eds.), *Proceedings, Mathematical Foundations of Programming Semantics, Thirteenth Annual Conference*, *Electronic Notes in Theoretical Computer Science* **6**, 1997.
URL: <http://www.elsevier.nl/cas/tree/store/tcs/free/noncas/pc/volume6.htm>
- [HP93] M. Hyland and V. de Paiva “Full intuitionistic linear logic (Extended Abstract)”, *Annals of Pure and Applied Logic* **64**, 3 (1993) 273–291.

- [KOS97] M. Kanovich, M. Okada, and A. Scedrov “Phase semantics for light linear logic”, in S. Brookes and M. Mislove (eds.), *Proceedings, Mathematical Foundations of Programming Semantics, Thirteenth Annual Conference*, Electronic Notes in Theoretical Computer Science **6**, 1997.
URL: <http://www.elsevier.nl/cas/tree/store/tcs/free/noncas/pc/volume6.htm>
- [LS86] J. Lambek and P.J. Scott *Introduction to Higher-Order Categorical Logic*. Cambridge Studies in Advanced Mathematics **7**, Cambridge University Press (1986).
- [R88] K.A. Rowe “Nuclearity”, *Canad. Math. Bull.* **31** (1988) 227–235.
- [Se89] R.A.G. Seely “Linear logic, *-autonomous categories and cofree coalgebras”, in J. Gray and A. Scedrov (eds.), *Categories in Computer Science and Logic*, Contemporary Mathematics **92** (Am. Math. Soc. 1989).

A Appendix: Nuclearity for linearly distributive categories

In this appendix we wish to show the connection between nuclear objects and complemented objects, and to prove that linear functors preserve complemented objects, which is the key ingredient in constructing a right adjoint to $U: *\text{-AUT} \rightarrow \text{LDC}$. First we need some definitions, and to be sure that the notion we define in linearly distributive categories is a good generalization of the corresponding notion for symmetric monoidal categories (in particular, in *-autonomous categories), we shall need some further discussion about nuclearity in linearly distributive categories. So we begin with somewhat of a long digression, before returning to our theme of linear functors.

We shall use the following terminology: a FILL category is a full multiplicative category, in the sense of Hyland and de Paiva [HP93], that is to say, a linearly distributive category which is also monoidal closed. We shall consider both symmetric and nonsymmetric FILL categories (as described in [CS97]), as well as the following variants: a left FILL category is a linearly distributive category with a “left” internal hom \multimap , and a right FILL category is a linearly distributive category with a “right” internal hom \multimap . The dual notions, where the closed structure is defined with respect to the cotensor (“par”), will be referred to as left (with \otimes) or right (with \otimes) coFILL categories.

Definition 28 *Suppose \mathbf{C} is a linearly distributive category; we shall say that a morphism $f: A \rightarrow B$ is **left nuclear** if there are morphisms*

$$\tau_f: \top \rightarrow C \oplus B \quad \gamma_f: A \otimes C \rightarrow \perp$$

such that the following commutes.

$$\begin{array}{ccccc}
 & & A & \xrightarrow{f} & B \\
 & u_{\otimes}^R \nearrow & & & \nwarrow u_{\oplus}^L \\
 A \otimes \top & & & & \perp \oplus B \\
 & 1 \otimes \tau_f \searrow & & & \nearrow \gamma_f \oplus 1 \\
 & & A \otimes (C \oplus B) & \xrightarrow{\delta_L^L} & (A \otimes C) \oplus B
 \end{array}$$

A left nuclear object A is an object A whose identity map is left nuclear.

Similarly, a morphism $f: A \rightarrow B$ is **right nuclear** if there are morphisms $\tau^f: \top \rightarrow B \oplus C$, $\gamma^f: C \otimes A \rightarrow \perp$ so that the evident diagram commutes; an object is right nuclear if its identity map is right nuclear.

We shall refer to the object C in these definitions as the *witness* of the nuclearity of f . When it is necessary to be more explicit, we shall say the triplet $\langle C, \tau_f, \gamma_f \rangle$ witnesses the nuclearity of f .

In terms of circuits, this says f is left nuclear if there is an equivalence as shown at the left below, and right nuclear if an equivalence as on the right below.

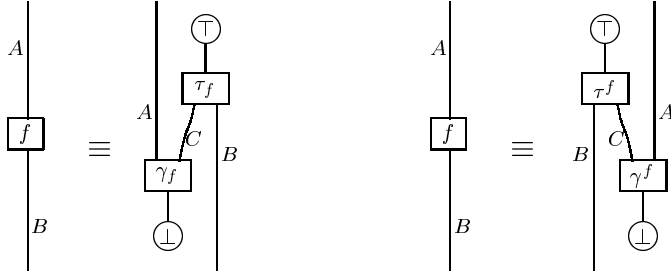

for some $\gamma_f, \tau_f, \gamma^f, \tau^f$.

In the symmetric case, the notions of left and right nuclear coincide, since one can easily convert witnesses of left nuclearity into witnesses of right nuclearity *via* a “twist”.

In a (left) FILL category, where we have an adjoint to $_ \otimes X$ for each X , any $\gamma_f: A \otimes C \rightarrow \perp$ can be “curried” to produce $\text{curry}(\gamma_f): C \rightarrow A \multimap \perp$, allowing the re-expression of the definition of nuclearity. In particular, this means that in place of γ_f we can use the evaluation map $A \otimes (A \multimap \perp) \xrightarrow{\text{ev}} \perp$, and adjust

τ_f to include the curried γ_f :

$$\tau_f; \text{curry}(\gamma_f) \oplus 1: \top \rightarrow (A \multimap \perp) \oplus B$$

This allows the re-expression of (left) nuclearity in a (left) FILL category as follows. (As usual, we write A^\perp for $A \multimap \perp$; note this is an “intuitionistic” negation, and is not an involution.)

Lemma 29 *f is left nuclear in a left FILL category if and only if there is a $n_f: \top \rightarrow A^\perp \oplus B$ such that the following commutes.*

$$\begin{array}{ccc} A & \xrightarrow{\widetilde{n}_f} & A \otimes (A^\perp \oplus B) \\ & \searrow f & \downarrow \phi \\ & & B \end{array}$$

where $\widetilde{n}_f = u_{\otimes}^{R^{-1}}; 1 \otimes n_f$ and $\phi = \delta_L^L; \text{ev} \oplus 1; u_{\oplus}^L$.

There is a dual lemma for right FILL categories, using ${}^\perp A = \perp \multimap A$ as the witness of nuclearity; we shall leave the statement of that to the reader. The proof of these lemmas is a simple exercise, and is also left to the reader.

This is clearly equivalent to the form used in [CS97], and is the natural generalization of the definition given by Rowe [R88] and by Higgs and Rowe [HR89] in the symmetric monoidal closed case. Our observation is that the assumption of closedness may be dropped, generalizing the definition to the context of linearly distributive categories. A basic property of nuclear maps is that they form a two-sided ideal, which we now establish.

Lemma 30 *The left (respectively right) nuclear maps of any linearly distributive category form a 2-sided ideal.*

Proof. We must establish that if f is nuclear (as witnessed by τ_f, γ_f), then so is $h; f; g$ for any (suitably “typed”) h, g . This is straightforward: $\tau_{h;f;g} = \tau_f; 1 \oplus g$ and $\gamma_{h;f;g} = h \otimes 1; \gamma_f$. That these maps work is immediately apparent from the following circuits. \square

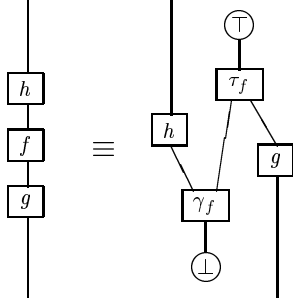

Proposition 31 *In any linearly distributive category \top and \perp are left and right nuclear, and if f, g are (left or right) nuclear maps, then so are $f \otimes g, f \oplus g$. More precisely:*

- (i) *the left nuclearity of \top is witnessed by $\tau_{\top} = (u_{\oplus}^L)^{-1}: \top \rightarrow \perp \oplus \top$ and $\gamma_{\top} = u_{\otimes}^L: \top \otimes \perp \rightarrow \perp$; the right nuclearity is similar, and the witnesses for \perp are dual.*
- (ii) *In addition, if f, g are left nuclear, then the left nuclearity of $f \otimes g$ is witnessed by $\gamma_{f \otimes g} = a_{\otimes}; 1 \otimes \delta_L^L; 1 \otimes (\gamma_g \oplus 1); 1 \otimes u_{\oplus}^L; \gamma_f$ and $\tau_{f \otimes g} = \tau_g; 1 \oplus (u_{\otimes}^R)^{-1}; 1 \oplus (\tau_f \otimes 1); 1 \oplus \delta_R^R; a_{\oplus}^{-1}$. Again, right nuclearity witnesses are similar, and the witnesses for $f \oplus g$ are dual.*

Proof. The proofs for \perp and \oplus are dual to those for \top and \otimes , so we show only the latter. That the witnesses given above satisfy the required coherence conditions is obvious from the following circuits. \square

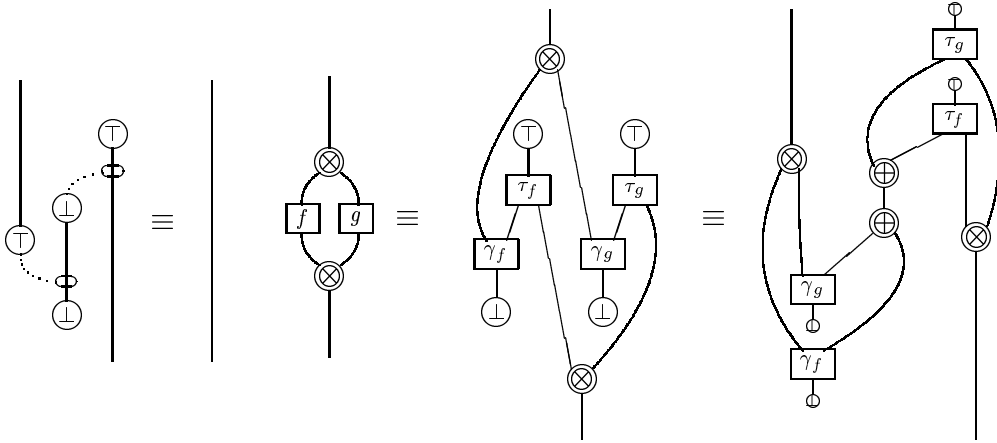

Notice that this result does not use the symmetry of the tensors, so it is true for the noncommutative case.

Definition 32 *In a linearly distributive category, an object A is a **left complement** if there is an object B (a right complement) and complementation morphisms τ_A^B, γ_A^B making A left nuclear and B right nuclear. We say*

$(A, \tau_A^B, \gamma_A^B, B)$ is a **complementation pair**; frequently we shall abuse the notation by dropping reference to some parts of this 4-tuple of entities, referring to just (A, B) or possibly just (τ_A^B, γ_A^B) as a complementation pair.

In circuits, this means we have this pair of figures.

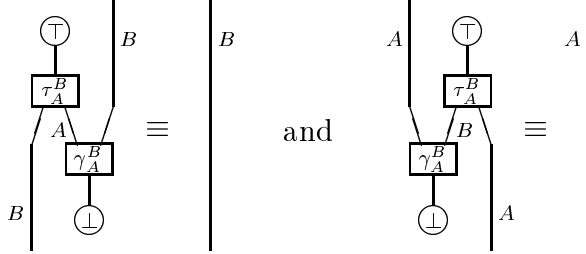

Lemma 33 *If (τ_A^B, γ_A^B) and $(\tau_A^{B'}, \gamma_A^{B'})$ are complementation pairs witnessing that A is left complemented, then there is a unique isomorphism $h: B \rightarrow B'$ such that the equation below for h holds.*

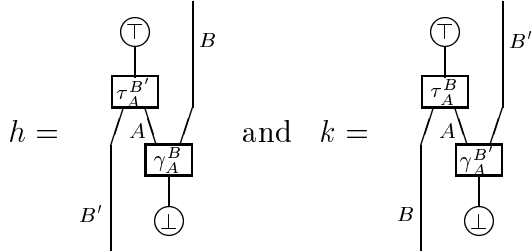

Proof. It suffices to show that h as above is an isomorphism. However it is clear that k (also as above) is its inverse. \square

Proposition 34 *Complemented objects are closed under \otimes, \oplus ; \top and \perp form a complementation pair.*

Proof. This is routine and essentially just follows the ideas of the proof of Proposition 31. We shall give an alternate proof at the end of the Appendix for the symmetric case (though the routine approach just outlined shows the result holds in the noncommutative case as well). \square

The observation we would have liked to make was that the full subcategory of (left) complemented objects forms a (left) $*$ -autonomous category (and similarly for right). However, there is a problem in the nonsymmetric case: a right complement may not itself be left complemented. We say, therefore, that an object is **strongly left complemented** in case it is left complemented and its right complement is strongly left complemented. (This is a recursive definition.) There is another minor matter: we have shown [CS92] that a linearly

distributive category which has a negation function is $*$ -autonomous, but we need an appeal to the axiom of choice if we wish to conclude that a linearly distributive category has this structure if we only know that every object has a (strong) complement. (The commutativity conditions do follow from one another; that is not the problem.) In Section 3 we discuss a way around this matter using sequences of objects, but the simpler approach does have its appeal, even if the ontological commitments are more severe.

The following result is now obvious.

Theorem 35 *In any linearly distributive category the strongly left complemented objects determine a full subcategory which is left $*$ -autonomous.*

Of course there are dual “right” notions. In the symmetric case we can drop the notions “strong”, “left”, and “right” to obtain a $*$ -autonomous category from the complemented objects.

Now we shall connect these two notions of complemented and nuclear objects. If A is a left nuclear object, its left nuclearity can be witnessed by several objects and morphisms. Consider two such objects B and B' , so

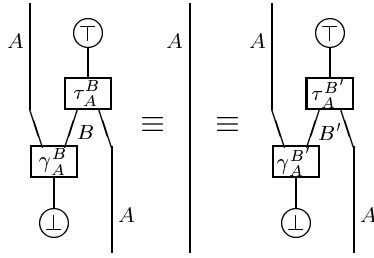

Clearly this gives two right nuclear maps $B \rightarrow B'$ and $B' \rightarrow B$ respectively:

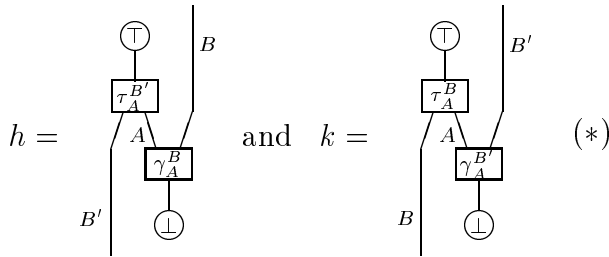

These maps, when composed, give idempotents on their source and targets, namely, the right nuclear maps resulting from reversing the action of the com-

plementation:

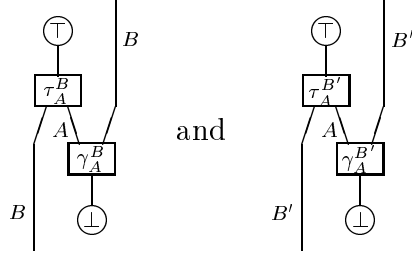

We call such idempotents **right complement idempotents**; note that such an idempotent $e: B \rightarrow B$ may be decomposed into the maps $(u_{\otimes}^L)^{-1}; \tau_A^B \otimes 1; \delta_R^R; 1 \oplus \gamma_A^B; u_{\oplus}^R: B \rightarrow B$ for a left nuclear object A . In a similar fashion right nuclear objects induce left complement idempotents (the circuit has the dual shape \cup). Note that not all idempotents are of this type; not even all nuclear idempotents (that is, idempotents that are nuclear maps) are complement idempotents. The essential ingredient that makes these idempotents special is that they embody witnesses of nuclearity, and so the dual composite is the identity on the corresponding nuclear object. For example, using the decomposition above, $(u_{\otimes}^R)^{-1}; 1 \otimes \tau_A^B; \delta_L^L; \gamma_A^B \oplus 1; u_{\oplus}^L: A \rightarrow A$ is the identity on A .

This class of idempotents may seem somewhat strange and arbitrary (for instance, it is not closed under composition); however, it is just what we need to compare nuclear objects with complemented ones.

Proposition 36 *If \mathbf{C} is a linearly distributive category, then left nuclear objects are left complements if and only if all right complement idempotents split.*

Proof. (\Rightarrow) Suppose e is a left complement idempotent (as above), so that $e = (u_{\otimes}^L)^{-1}; \tau_A^B \otimes 1; \delta_R^R; 1 \oplus \gamma_A^B; u_{\oplus}^R: B \rightarrow B$ and $(u_{\otimes}^R)^{-1}; 1 \otimes \tau_A^B; \delta_L^L; \gamma_A^B \oplus 1; u_{\oplus}^L: A \rightarrow A$ is the identity on A . Then A is left nuclear, so is a left complement, with a right complement, C say. It then is an easy exercise to show that the evident \cap -shape maps “through” C split $e: r = (u_{\otimes}^L)^{-1}; \tau_A^C \otimes 1; \delta_R^R; 1 \oplus \gamma_A^B; u_{\oplus}^R: C \rightarrow B$ and $s = (u_{\otimes}^L)^{-1}; \tau_A^B \otimes 1; \delta_R^R; 1 \oplus \gamma_A^C; u_{\oplus}^R: B \rightarrow C$. (The calculation is similar to that below in the proof of the converse: place the two \cap shapes together, cancel the middle, and see the result is e one way, and 1 the other.)

(\Leftarrow) Let (τ_A, γ_A) witness the left nuclearity of A ; then form the (by now familiar \cap shape) right complement idempotent $h = (u_{\otimes}^L)^{-1}; \tau_A \otimes 1; \delta_R^R; 1 \oplus \gamma_A; u_{\oplus}^R: C \rightarrow C$. This may be split: $h = e_h; m_h$ and $m_h; e_h = 1_C$. Set $\tau_A^C = \tau_A; e_h \oplus 1$ and $\gamma_A^C = 1 \otimes m_h; \gamma_A$; then the following simple calculation shows that (τ_A^C, γ_A^C) is a complementation pair. \square

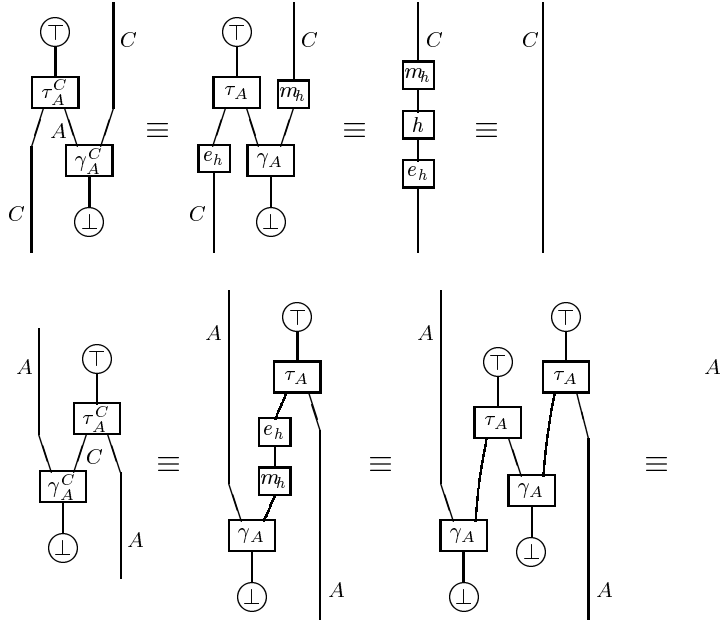

Note that if *all* left nuclear idempotents split, so that certainly the right complement idempotents split, then the notion of right nuclear and right complemented object coincide. While nuclear idempotents are not generally complement idempotents, when all nuclear idempotents split these two notions do coincide.

Lemma 37 *In a linearly distributive category, any right nuclear idempotent whose corresponding left nuclear idempotents split, is a right complement idempotent, where a “corresponding idempotent” is obtained by reversing the action of the witness maps.*

Proof. Let e be a right nuclear idempotent. Then we have

$$e = \begin{array}{c} \textcircled{T} \\ | \\ \boxed{\tau_e} \\ | \quad | \\ \boxed{\gamma_e} \\ | \\ \textcircled{\perp} \end{array} \quad \text{and} \quad \begin{array}{c} \textcircled{T} \\ | \\ \boxed{\tau_e} \\ | \quad | \\ \boxed{\gamma_e} \\ | \\ \textcircled{\perp} \end{array} = e'$$

is a left nuclear idempotent. e' can then be split: $e' = r; s$, where $s; r = 1_C$. Now, $\tau_e; 1 \oplus r = \tau_C$ and $s \otimes 1; \gamma_e = \gamma_C$ witnesses the left nuclearity of C , by the argument above. This means e is a right complement idempotent. \square

Now we return to the FILL category case. There, the special nature of com-

plementation simplifies matters.

Proposition 38 *If \mathbf{C} is a left FILL category, then every left nuclear object is a left complement.*

This is an immediate consequence of the following lemma.

Lemma 39 *In a left FILL category, all right complement idempotents split.*

Proof. Let e be a right complement idempotent, so that $e = (u_{\otimes}^L)^{-1}; \tau_A^B \otimes 1; \delta_R^R; 1 \oplus \gamma_A^B; u_{\oplus}^R; B \rightarrow B$ for a left nuclear object A . As we saw in the discussion before Lemma 29, this means γ_A^B can be carried to give a map $c: B \rightarrow A^\perp$ so that $\gamma_A^B = 1 \otimes c; \text{ev}$. There is a canonical map $A^\perp \rightarrow B$ induced by τ_A^B , and it is evident that e is the composite of this with c . We have to show that the other composite, *viz.* the induced right idempotent on A^\perp , is the identity. The circuit equivalences below show this, starting with the circuit for the idempotent on A^\perp and ending with the expanded normal form of the identity on A^\perp . \square

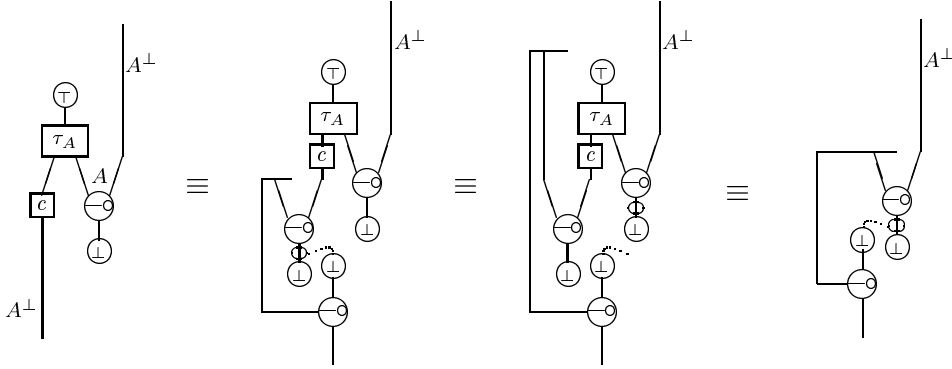

Remark A linearly distributive category may have no nontrivial nuclear objects and yet the category may have nuclear idempotents. These, when suitably split, will themselves generate a nontrivial $*$ -autonomous category.

Finally, we are ready to return to the main theme of this paper, with the following proposition.

Proposition 40 *Linear functors preserve nuclear morphisms and objects.*

Specifically, if $F: \mathbf{X} \rightarrow \mathbf{Y}$ is a linear functor of linearly distributive categories, and if f is (left) nuclear in \mathbf{X} , then both $F_{\otimes}(f), F_{\oplus}(f)$ are (left) nuclear in \mathbf{Y} , and similarly for right nuclear maps. Moreover, if the left nuclearity of f is witnessed by an object C , so that there are maps $\tau_f: \top \rightarrow C \oplus B$ and $\gamma_f: A \otimes C \rightarrow \perp$ such that $f = A \xrightarrow{u^{-1}} A \otimes \top \xrightarrow{1 \otimes \tau_f} A \otimes (C \oplus B) \xrightarrow{\delta_L^f} (A \otimes C) \oplus B$

$\xrightarrow{\gamma_f \oplus 1} \perp \oplus B \xrightarrow{u} B$, then the (left) nuclearity of $F_\otimes(f)$ is witnessed by $F_\oplus(C)$:

$$\top \xrightarrow{m_\top} F_\otimes(\top) \xrightarrow{F_\otimes(\tau_f)} F_\otimes(C \oplus B) \xrightarrow{\nu_\otimes^R} F_\oplus(C) \oplus F_\otimes(B)$$

$$F_\otimes(A) \otimes F_\oplus(C) \xrightarrow{\nu_\oplus^R} F_\oplus(A \otimes C) \xrightarrow{F_\oplus(\gamma_f)} F_\oplus(\perp) \xrightarrow{n_\perp} \perp$$

and dually for $F_\oplus(f)$, and similarly for right nuclearity.

Proof. We shall do the case of the left nuclearity of $F_\otimes(f)$, leaving the other cases to the reader. We have given the appropriate witness above; we must check that the appropriate composition gives $F_\otimes(f)$. This amounts to showing that the outer paths of the rectangle in Figure A.1 commute. Note that the left-bottom path is just the image under F of the composite that gives f since f is nuclear. (We have indicated in the cells whether they commute because of naturality (nat), because the functor is linear (lin), or the functor is monoidal (mon .) The reader might like to try this using circuits: it is easy to get a simple “one-line” proof corresponding to the diagram decomposition in Figure A.1. If one puts a F_\otimes functor box around each side of the defining circuit equation expressing that f is left nuclear, and then splits the F_\otimes box around the \cup^\cap circuit (involving the τ and γ nodes) using the fourth equivalence from Table 1, one obtains a new \cup^\cap shape involving a F_\otimes box with a τ node inside, and a F_\oplus box with a γ node inside, showing that $F_\otimes(f)$ is left nuclear with $F_\oplus(C)$ as witness. With the other cases done dually, this completes the proof. \square

Corollary 41 *Linear functors preserve complemented objects.*

Specifically, if $F: \mathbf{X} \rightarrow \mathbf{Y}$ is a linear functor of linearly distributive categories, and if A is (left) complemented in \mathbf{X} , then both $F_\otimes(f), F_\oplus(f)$ are (left) complemented in \mathbf{Y} , and similarly for right complements.

Proof. The proof is immediate from the Proposition and proof above; note that the witness of the left nuclearity of (say) the identity on $F_\otimes(A)$ will be $F_\oplus(B)$, where B is the right complement of A . \square

Note that this gives another proof, at least in the symmetric case, that complemented objects are closed under \otimes, \oplus , and that \top and \perp form a complementation pair, since we just need to apply the preceding Corollary to the linear functor \otimes .

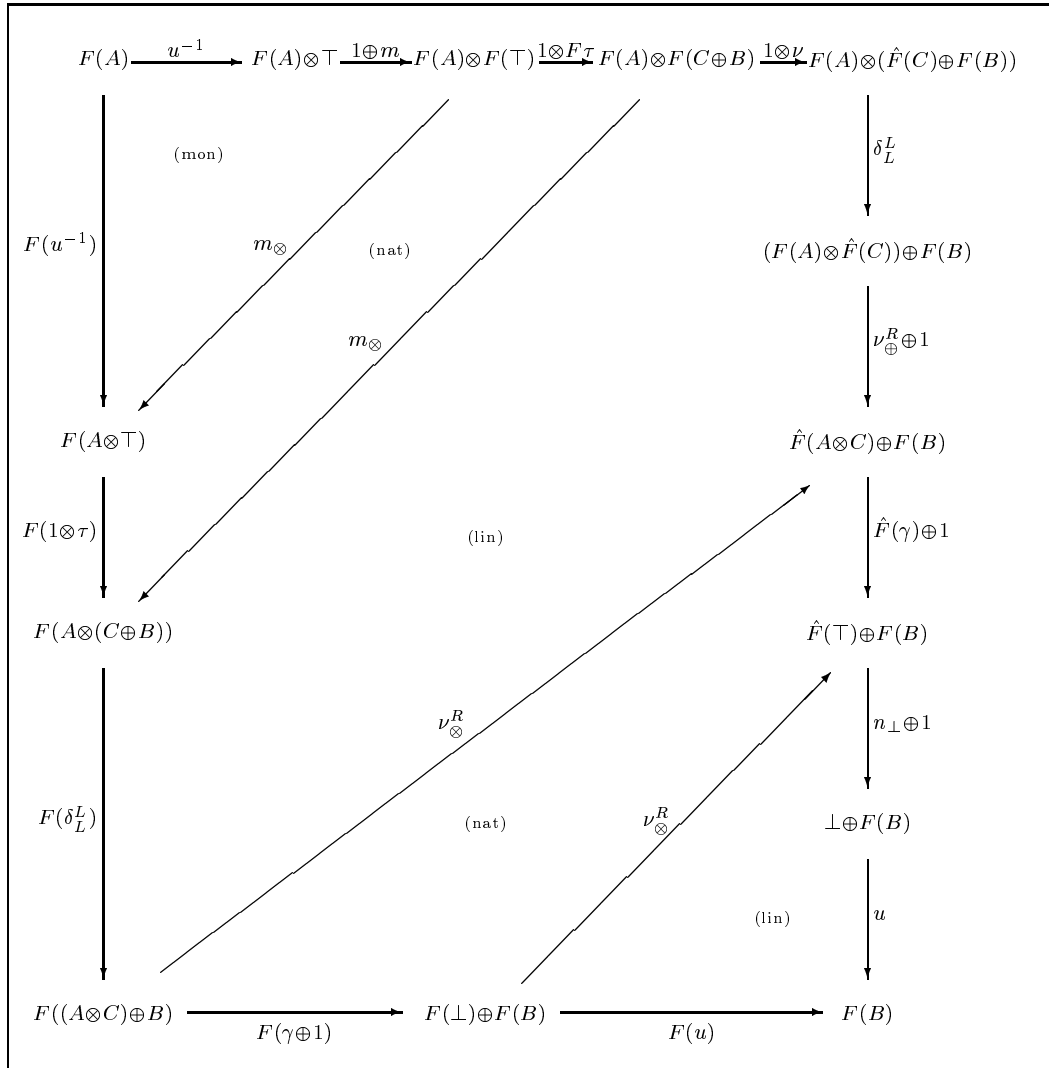

Fig. A.1. Linear F preserves nuclear f